

# SHOUT sp USER GUIDE

451-93281-001D

Version D

April 19, 2023



## LEGAL DISCLAIMER AND CONDITION OF USE

This document contains information for the SHOUT sp Iridium smartphone, personal satellite tracking device and accompanying accessories (“Product”), which is provided “as is.” Reasonable effort has been made to make the information in this document reliable and consistent with specifications, test measurements and other information. However, NAL Research Corporation and its affiliated companies, directors, officers, employees, agents, trustees or consultants (“NAL Research”) assume no responsibility for any typographical, technical, content or other inaccuracies in this document. NAL Research reserves the right in its sole discretion and without notice to you to change Product specifications and materials and/or revise this document or withdraw it at any time. User assumes the full risk of using the Product specifications and any other information provided.

NAL Research makes no representations, guarantees, conditions or warranties, either express or implied, including without limitation, any implied representations, guarantees, conditions or warranties of merchantability and fitness for a particular purpose, non-infringement, satisfactory quality, non-interference, accuracy of informational content, or arising from a course of dealing, law, usage, or trade practice, use, or related to the performance or nonperformance of any products, accessories, facilities or services or information except as expressly stated in this guide and/or the Product and/or satellite service documentation. Any other standards of performance, guarantees, conditions and warranties are hereby expressly excluded and disclaimed to the fullest extent permitted by the law. This disclaimer and exclusion shall apply even if the express limited warranty contained in this guide or such documentation fails of its essential purpose.

In no event shall NAL Research be liable, whether in contract or tort or any other legal theory, including without limitation strict liability, gross negligence or negligence, for any damages in excess of the purchase price of the Product, including any direct, indirect, incidental, special or consequential damages of any kind, or loss of revenue or profits, loss of business, loss of privacy, loss of use, loss of time or inconvenience, loss of information or data, software or applications or other financial loss caused by the Product (including hardware, software and/or firmware) and/or the Iridium satellite, or arising out of or in connection with the ability or inability to use the Product (including hardware, software and/or firmware) and/or the Iridium satellite to the fullest

extent these damages may be disclaimed by law and whether advised of the possibilities of such damages. NAL Research is not liable for any claim made by a third party or made by you for a third party.

## REVISION HISTORY

Revision	Date	Description
A	03/17/2021	Initial version
B	10/22/2021	Rev C Hardware update
C	02/23/2022	Updated screen shots, and performed editorial updates
D	03/19/2023	- Added SHOUT sp Mount (Appendix F) - Updated section 8.3.9 Configure from File

## REFERENCE DOCUMENTS

The latest revision of these documents are available from the NAL Research website at (<https://www.nalresearch.com/>).

**Table 1: Reference Documents**

Reference	Title	Revision/Date
[1]	Security Requirements for Cryptographic Modules, FIPS PUB 140-2, US Department of Commerce, National Institute of Standards and Technology	May 25, 2001
[2]	Security Requirements for Cryptographic Modules, Annex A: Approved Security Functions for FIPS PUB 140-2, US Department of Commerce, National Institute of Standards and Technology	February 19, 2003
[3]	PECOS Message Definition Specification, 200907-001	Version 1.7 July 29, 2009

# TABLE OF CONTENTS

<b>1 INTRODUCTION.....</b>	<b>16</b>
<b>2 USING THE SHOUT SP .....</b>	<b>19</b>
2.1 Device Description.....	19
2.2 Accessories .....	20
2.2.1 SHOUT sp.....	20
2.2.2 SHOUT sp Mount kit .....	20
2.3 Charging the Battery.....	21
2.4 Power On/Off & Awaken, Reboot.....	21
2.5 Touchscreen.....	22
2.6 Basic Navigation.....	23
2.7 Network Operating Center (NOC).....	23
2.8 Server for Tracker Software .....	23
2.9 NAL Vue .....	24
<b>3 HOME SCREEN .....</b>	<b>25</b>
3.1 Status Symbols.....	26
3.2 Favorite Icons.....	26
<b>4 QUICK START .....</b>	<b>27</b>
<b>5 SHOUT SP DISPLAY .....</b>	<b>29</b>
5.1 Home Screen .....	29
<b>6 MAKING A PHONE CALL .....</b>	<b>30</b>
6.1 From the Android Keypad.....	30
6.2 From Android Contacts.....	31
<b>7 IRIDIUM SHORT MESSAGE SERVICE (SMS).....</b>	<b>34</b>
<b>8 NAL SHOUT APP .....</b>	<b>35</b>
8.1 Short Burst Data (SBD) Texting Menu.....	35
8.1.1 Texting .....	36
8.1.2 Inbox .....	36
8.1.3 Outbox .....	36
8.1.4 Drafts.....	38
8.1.5 Sent.....	38
8.1.6 Compose .....	38
8.1.6.1 Compose Email .....	38
8.1.6.2 Select Message Recipients from Contacts List .....	39
8.1.6.3 Enter Message Recipients' Email Address(es).....	40
8.1.6.4 Send a Canned/Free-text Message .....	40
8.1.7 Can'd Msgs .....	42
8.1.8 Contacts.....	43
8.1.9 Mbox Rate .....	44

8.2 Tracking Menu .....	45
8.2.1 Tracking .....	45
8.2.2 Rpt Rate .....	45
8.2.3 Call Outs.....	46
8.2.4 Brevity.....	47
8.2.5 Stats.....	47
8.2.6 End Emer.....	48
8.2.7 Utilities Menu .....	49
8.2.8 Chk GPS.....	50
8.2.9 Chk-In.....	50
8.2.10 Chk Iridium.....	51
8.2.11 Test Rpt .....	51
8.2.12 Waypts.....	52
8.3 Settings Menu.....	53
8.3.1 Settings .....	53
8.3.2 Display .....	54
8.3.2.1 Position Format .....	54
8.3.2.2 Time Zone .....	54
8.3.3 GPS.....	55
8.3.3.1 Invalid Course Value .....	55
8.3.3.2 Position Model.....	56
8.3.4 LED.....	57
8.3.5 Security .....	58
8.3.5.1 Encryption.....	58
8.3.5.2 Access Control List.....	59
8.3.6 Texting .....	59
8.3.6.1 Mailbox Check and Mailbox Check Rate options .....	60
8.3.6.2 Include GPS.....	60
8.3.6.3 Text Message Format .....	60
8.3.7 Tracking .....	61
8.3.7.1 Tracking.....	61
8.3.7.2 Tracking Profiles .....	61
8.3.7.3 Brevity Code.....	66
8.3.7.4 Data Log.....	67
8.3.7.5 Remote Message Format .....	67
8.3.7.6 GPS Always On.....	67
8.3.8 Max Queued Reports.....	68
8.3.8.1 Motion .....	68
8.3.8.2 Remote Update Time Check.....	68
8.3.8.3 Successful Send Required.....	69
8.3.9 Configure From File .....	69
<b>9 NAL PUSH-TO-TALK [PTT] APP.....</b>	<b>79</b>
9.1 Launching and Unlocking the PTT App.....	80
9.2 PTT App Screens .....	80
9.2.1 Mode Selection .....	80

9.2.2	911 Status .....	81
9.2.3	Idle and Scanning State .....	82
9.2.4	Open and Listening State .....	84
9.2.5	Talking and Denied State .....	85
9.3	PTT Options and Settings Menu .....	86
9.3.1	Switch to Phone .....	86
9.3.2	PTT Refresh Talkgroup .....	87
9.3.3	Talkgroup Selection .....	87
9.3.4	PTT Options .....	88
9.3.5	Audio Options .....	89
<b>APPENDIX A: PMS FEATURES .....</b>		<b>91</b>
A-1.	Tracking .....	91
A-2.	Brevity .....	91
A-3.	Contacts .....	91
A-4.	Compose .....	91
<b>APPENDIX B: UPGRADING THE FIRMWARE .....</b>		<b>92</b>
<b>APPENDIX C: DESIGN SPECIFICATIONS .....</b>		<b>93</b>
C-1.	SHOUT sp .....	93
C-2.	Shout sp Mount Design Specifications .....	95
<b>APPENDIX D: STANDARD COMPLIANCE .....</b>		<b>101</b>
<b>APPENDIX E: EXPORT COMPLIANCE .....</b>		<b>102</b>
<b>APPENDIX F: SHOUT SP MOUNT KIT .....</b>		<b>103</b>
F-1.	SHOUT sp Mount Components .....	104
F-1.1.	Twist-Lock Suction Cup Mount .....	104
F-1.2.	Screw-Down Plate Mount .....	104
F-1.3.	Cradle Assembly .....	105
F-1.3.1.	Grip .....	106
F-1.3.2.	Audio Amplifier Module .....	106
F-1.4.	Handheld Speaker-Microphone .....	109
F-1.5.	Car Charger .....	110
F-1.6.	Car Charger USB-C Power Cable .....	111
F-1.7.	AC Wall Mount Power Cable .....	111
F-1.8.	AC Adapter Wall Mount w/AC Clip .....	111
F-2.	Installation .....	112
F-2.1.	SHOUT sp Mount (Suction Cup) .....	112
F-2.2.	SHOUT SP Mount (Screw-Down Plate) .....	113
F-2.3.	Car Charger .....	114
F-2.4.	AC Adapter Wall Mount .....	115
F-3.	Load and Operate SHOUT SP Device .....	116



# TABLE OF FIGURES

FIGURE 1: SHOUT SP VIEWS AND FEATURES .....	19
FIGURE 2: SHOUT SP ACCESSORIES .....	20
FIGURE 3: SHOUT SP MOUNT (SUCTION CUP) .....	20
FIGURE 4: POWER BUTTON.....	22
FIGURE 5: BACK ARROW BUTTON .....	23
FIGURE 6: SHOUT SP HOME SCREEN .....	25
FIGURE 7: ANDROID APP SCREEN BUTTON.....	29
FIGURE 8: PRELOADED ANDROID APPS.....	29
FIGURE 9: ANDROID PHONE KEYPAD .....	30
FIGURE 10: CALL ICON .....	31
FIGURE 11: CREATE A NEW CONTACT .....	32
FIGURE 12: CONTACT INFO .....	32
FIGURE 13: CONTACTS LIST.....	32
FIGURE 14: CREATE LIST.....	33
FIGURE 15: CONTACT INFORMATION .....	33
FIGURE 16: TRACKING APP MAIN MENU .....	35
FIGURE 17: TEXTING MENU.....	35
FIGURE 18: INBOX.....	36
FIGURE 19: OUTBOX .....	36
FIGURE 20: DRAFTS.....	38
FIGURE 21: EMPTY COMPOSE SCREEN .....	39
FIGURE 22: COMPOSE AND SELECT CONTACT OPTION.....	39
FIGURE 23: COMPOSE AND ENTER EMAIL OPTION .....	40
FIGURE 24: CANNED MESSAGES LIST .....	41
FIGURE 25: COMPOSE WITH CANNED MESSAGE .....	41
FIGURE 26: SELECT DIFFERENT CANNED MESSAGE .....	42
FIGURE 27: REORDERING CANNED MESSAGES.....	43
FIGURE 28: NEW CANNED MESSAGE .....	43
FIGURE 29: CONTACT LIST DISPLAY .....	44

FIGURE 30: EDIT CONTACT .....	44
FIGURE 31: NEW CONTACT .....	44
FIGURE 32: MAILBOX CHECK RATE.....	44
FIGURE 33: TRACKING MENU.....	45
FIGURE 34: REPORTING RATE ENABLED.....	46
FIGURE 35: REPORTING RATE DISABLED.....	46
FIGURE 36: CALL OUTS .....	47
FIGURE 37: BREVIETY CODE .....	47
FIGURE 38: STATISTICS.....	48
FIGURE 39: END EMERGENCY.....	49
FIGURE 40: UTILITIES MENU .....	49
FIGURE 41: CHECK GPS.....	50
FIGURE 42: CHECK-IN.....	50
FIGURE 43: CHECK IRIDIUM .....	51
FIGURE 44: TEST REPORT .....	51
FIGURE 45: WAYPOINTS.....	53
FIGURE 46: NEW WAYPOINT .....	53
FIGURE 47: WAYPOINT SELECTED .....	53
FIGURE 48: SETTINGS .....	53
FIGURE 49: POSITION FORMAT.....	54
FIGURE 50: DISPLAY MENU .....	54
FIGURE 51: TIME ZONE.....	55
FIGURE 52: GPS.....	55
FIGURE 53: INVALID COURSE VALUE.....	55
FIGURE 54: POSITION MODEL .....	55
FIGURE 55: LED OPTION SCREEN .....	57
FIGURE 56: SECURITY SETTING MENU.....	58
FIGURE 57: ENCRYPTION .....	58
FIGURE 58: CRYPTO OFFICER PASSWORD .....	58
FIGURE 59: ENCRYPTION KEY .....	59
FIGURE 60: DECRYPTION KEY .....	59

FIGURE 61: ACL SETTINGS .....	59
FIGURE 62: TEXTING.....	60
FIGURE 63: MAILBOX CHECK RATE.....	60
FIGURE 64: TEXT MESSAGE FORMAT .....	61
FIGURE 65: TRACKING (PART 1) .....	61
FIGURE 66: TRACKING (PART 2) .....	61
FIGURE 67: TRACKING PROFILES (PART 1) .....	63
FIGURE 68: TRACKING PROFILES (PART 2) .....	63
FIGURE 69: TIME BETWEEN REPORTS.....	63
FIGURE 70: TIME TO KEEP TRYING .....	64
FIGURE 71: DELAY FIRST REPORT .....	64
FIGURE 72: SKIP REPORTING WHEN STATIONARY MENU.....	65
FIGURE 73: SKIP REPORTING WHEN STATIONARY MODE.....	65
FIGURE 74: MOTION .....	68
FIGURE 75: MOTION SENSOR REPORTING .....	68
FIGURE 76: SUCCESSFUL SEND REQUIRED.....	69
FIGURE 77: SWIPE DOWN .....	70
FIGURE 78: TAP USB FOR CHARGING.....	70
FIGURE 79: SELECT FILE TRANSFERS.....	70
FIGURE 80: WINDOWS AUTOPLAY .....	71
FIGURE 81: AUTOPLAY OPTIONS .....	71
FIGURE 82: LAUNCH FILE EXPLORER .....	72
FIGURE 83: FIND THE XML FILE .....	72
FIGURE 84: COPY THE XML FILE .....	72
FIGURE 85: SHOUT SP ICON .....	73
FIGURE 86: COPY THE XML FILE .....	73
FIGURE 87: LAUNCH THE SP APP.....	74
FIGURE 88: TAP SETTINGS .....	74
FIGURE 89: TAP 3 DOTS AT THE TOP RIGHT OF THE SETTING SCREEN .....	74
FIGURE 90: TAP CONFIGURE FROM FILE .....	74
FIGURE 91: TAP RECENT .....	75

FIGURE 92: TAP RECENT OPTIONS MENU.....	75
FIGURE 93: TAP 3 LINE ICON.....	75
FIGURE 94: TAP SHOW INTERNAL STORAGE .....	75
FIGURE 95: TAP 3 LINE ICON .....	76
FIGURE 96: TAP SHOW INTERNAL STORAGE.....	76
FIGURE 97: TAP RECENT TO SEE OPEN MENU .....	77
FIGURE 98: CONFIGURE CONFIRMATION .....	77
FIGURE 99: TAP DONE TO CLOSE THE PROCESS.....	77
FIGURE 100: MODE SELECT.....	79
FIGURE 101: PTT MODE .....	79
FIGURE 102: PTT PASSWORD ENTRY .....	80
FIGURE 103: PTT REGISTRATION.....	81
FIGURE 104: EMERGENCY MODE.....	82
FIGURE 105: PTT IDLE .....	83
FIGURE 106: PTT SCANNING .....	83
FIGURE 107: PTT LISTENING .....	84
FIGURE 108: PTT PRIORITY TALKGROUP LISTENING .....	84
FIGURE 109: PTT TALKING.....	85
FIGURE 110: PTT DENIED TALKING.....	85
FIGURE 111: SWITCH MODE.....	86
FIGURE 112: SWITCH CONFIRMATION .....	86
FIGURE 113: PTT MENU .....	87
FIGURE 114: PTT REFRESH TALKGROUP.....	87
FIGURE 115: PTT MENU .....	88
FIGURE 116: TALKGROUP LIST.....	88
FIGURE 117: PTT MENU .....	89
FIGURE 118: PTT SCANNING .....	89
FIGURE 119: PTT MENU .....	90
FIGURE 120: AUDIO OPTIONS.....	90
FIGURE 121: SHOUT SP MOUNT (SUCTION CUP) .....	104
FIGURE 122: SHOUT SP MOUNT (SCREW-DOWN PLATE).....	104

FIGURE 123: KIT WITH TWIST-LOCK SUCTION CUP MOUNT .....	105
FIGURE 124: KIT WITH SCREW-DOWN PLATE MOUNT .....	105
FIGURE 125: CRADLE ASSEMBLY – FRONT VIEW .....	107
FIGURE 126: CRADLE ASSEMBLY – TOP VIEW .....	107
FIGURE 127: CRADLE ASSEMBLY – BOTTOM VIEW .....	108
FIGURE 128: BOTTOM VIEW: AUDIO AMPLIFIER MODULE.....	108
FIGURE 129: TOP VIEW: AUDIO AMPLIFIER MODULE .....	109
FIGURE 130: FRONT VIEW.....	109
FIGURE 131: PARTIAL SIDE VIEW .....	110
FIGURE 132: REAR VIEW.....	110
FIGURE 133: CAR CHARGER.....	110
FIGURE 134: CAR CHARGER USB-C POWER CABLE (3FT).....	110
FIGURE 135: DOCKING STATION POWER CABLE (6FT) .....	111
FIGURE 136: WALL MOUNT AC INTERCHANGEABLE ADAPTER.....	112
FIGURE 137: AC CLIP - USA.....	112
FIGURE 138: AC CLIP – UK.....	112
FIGURE 139: SUCTION CUP MOUNT.....	113
FIGURE 140: TEMPLATE .....	113
FIGURE 141: SCREW-DOWN MOUNTING PLATE .....	114
FIGURE 142: CRADLE ASSEMBLY – BOTTOM VIEW .....	115
FIGURE 143: POWER USB-C CABLE CONNECTED TO CAR CHARGER .....	115
FIGURE 144: USB-C CONNECTION AC ADAPTER WALL MOUNT .....	116
FIGURE 145: USB-C CONNECTOR PORT ON AUDIO BOX.....	116
FIGURE 146: MOUNTED SHOUT SP DEVICE .....	117
FIGURE 147: USB-C INTERFACE CONNECTION .....	118
FIGURE 148: AUDIO INTERFACE CONNECTION .....	118
FIGURE 149: SPEAKER-MICROPHONE CABLE CONNECTED TO AUDIO BOX.....	119
FIGURE 150: HANDHELD SPEAKER-MICROPHONE CLIP.....	119
FIGURE 151: SPEAKER-MICROPHONE MOUNTING BRACKET .....	120
FIGURE 152: POWER CONNECTION TO AUDIO BOX .....	121
FIGURE 153: RUBBER BALL SOCKET SYSTEM .....	122

FIGURE 154: SPEAKER-MICROPHONE PTT SWITCH AND HI/LOW TOGGLE SWITCH ..... 123

## TABLE OF TABLES

TABLE 1: REFERENCE DOCUMENTS ..... 5  
 TABLE 2: STATUS SYMBOLS ..... 26  
 TABLE 3: POSITION MODEL REFERENCE TABLE..... 56

## ACRONYM LIST

ACL	Access Control List
AES	Advanced Encryption Standard
BIS	Bureau of Industry and Security
CE	Conformité Européenne
CEP	Circular Error Probability
DoD	Department of Defense
DoD EMSS	DoD Enhanced Mobile Satellite Services
EAR	Export Administration Regulations
ETSI	<i>European Telecommunications Standards Institute</i>
FCC	Federal Communications Commission
FDMA	Frequency Division Multiple Access
GPS	Global Positioning System
HACC	Horizontal Accuracy
HDOP	Horizontal Dilution of Precision
IC	Industry Canada
IMEI	International Mobile Equipment Identification
LBT	L-Band Transceiver
LCD/LED	Liquid Crystal Display, Light Emitting Diode
LNA	Low Noise Amplifier
NOC	Network Operation Center

---

OFAC.....Office of Foreign Asset Controls  
PMS .....PECOS Message Structure  
POP.....Post Office Protocol  
RF.....Radio Frequency  
RUDICS .....Router-Based Unrestricted Digital Internetworking Connectivity Solution  
SBAS .....Satellite Based Augmentation System  
SBD .....Short Burst Data  
SMS .....Short Message Service  
SMTP .....Simple Mail Transfer Protocol  
TDD.....Time Division Duplex  
TDMA .....Time Division Multiple Access  
UTC.....Coordinated Universal Time  
USB.....Universal Serial Bus  
VDOP .....Vertical Dilution of Precision

# 1 INTRODUCTION

The SHOUT sp is an Android-based smartphone which uses Iridium® telephone voice service and Iridium SMS text message capabilities through the organic Android phone and text applications. The SHOUT sp is designed for use solely over the Iridium satellite constellation. It is not capable of operations over cellular networks.

Additionally, the tracking and messaging capabilities of the SHOUT family of products are incorporated through the NAL SHOUT App, displayed on the device homepage as an Android icon for quick access. The NAL App relies on Iridium's Short Burst Data® (SBD) message format to transmit both message and tracking data to a Network Operations Center (NOC). On the commercial gateway, global Push-To-Talk (PTT) service is also supported and in future releases, AES-256 voice encryption and low-power tracking will be added as software upgrades.

The SHOUT sp offers a variety of services including:

- Normal Tracking Operations – Programmed to automatically wake up and send a position report at a set interval ranging from once a minute to once every seven days.
- Emergency Tracking Operations – Sends alerts to a designated monitoring center using an Emergency button. The monitoring center and the user may then communicate to define further specifics of the emergency.
- Canned Text Messaging — Allows the user to send canned (predefined) messages stored in device memory. Sending canned messages saves bandwidth (and airtime cost) because only short codes are transmitted to the server instead of the entire message body.
- Waypoint Tracking — Lets the user send and/or save waypoints for later retrieval. A waypoint is a GPS location that a user wants to identify and mark with a specific name tag for future reference.
- Check-In — Allows a quick check-in message to be sent.
- Integrated 5-megapixel Camera with Flash.
- Push-to-Talk – Full push-to-talk capability with a single button on the side of the device using Iridium's Commercial PTT service.



- Low Power Tracking – Allows tracking with the Android framework powered off to maximize battery life and the number of reports.
- AES-256 Voice Encryption – (FUTURE RELEASE) Encryption of circuit-switched voice calls.

The SHOUT sp reporting formats are 100% compatible with SHOUT, SHOUT nano and SHOUT ts when using the Iridium link.

The SHOUT sp main application menu options are displayed as icons for quick access. The device can periodically wake up from sleep to send its position report to a Network Operation Center (NOC). The SHOUT sp reporting formats are 100% compatible with the SHOUT, SHOUT nano and SHOUT ts when using the Iridium link. Data are packaged in either unencrypted or 256-bit AES encrypted format. The 256-bit AES encryption algorithms for data implemented in the SHOUT sp comply with NIST FIPS140-2 (see documents *Security Requirements for Cryptographic Modules, FIPS PUB 140-2, US Department of Commerce, National Institute of Standards and Technology, May 25, 2001* [1] and *Security Requirements for Cryptographic Modules, Annex A: Approved Security Functions for FIPS PUB 140-2, US Department of Commerce, National Institute of Standards and Technology, February 19, 2003* [2]).

The SHOUT sp is capable of sending position reports and text messages in PECOS Message Structure (PMS). The PMS complies with the Blue Force Tracking Data Format Specification as defined in the document *PECOS 200907-001 Version 1.7* [3]. Functions related to PMS can be found in Appendix A: PMS Features.

**IMPORTANT:** The SHOUT sp is capable of operation on the Iridium DoD EMSS Gateway when it is equipped with a DISA EMSS Iridium SIM card. However, accessing the EMSS Gateway is not authorized until the SHOUT sp is provisioned (signed up for airtime). Unauthorized attempts to access the EMSS Gateway will result in immediate disabling of the offending device, which must then be returned to NAL Research for repair. See the webpage <https://emss.pac.disa.mil> for more information regarding DoD EMSS SIM cards and service provisioning.

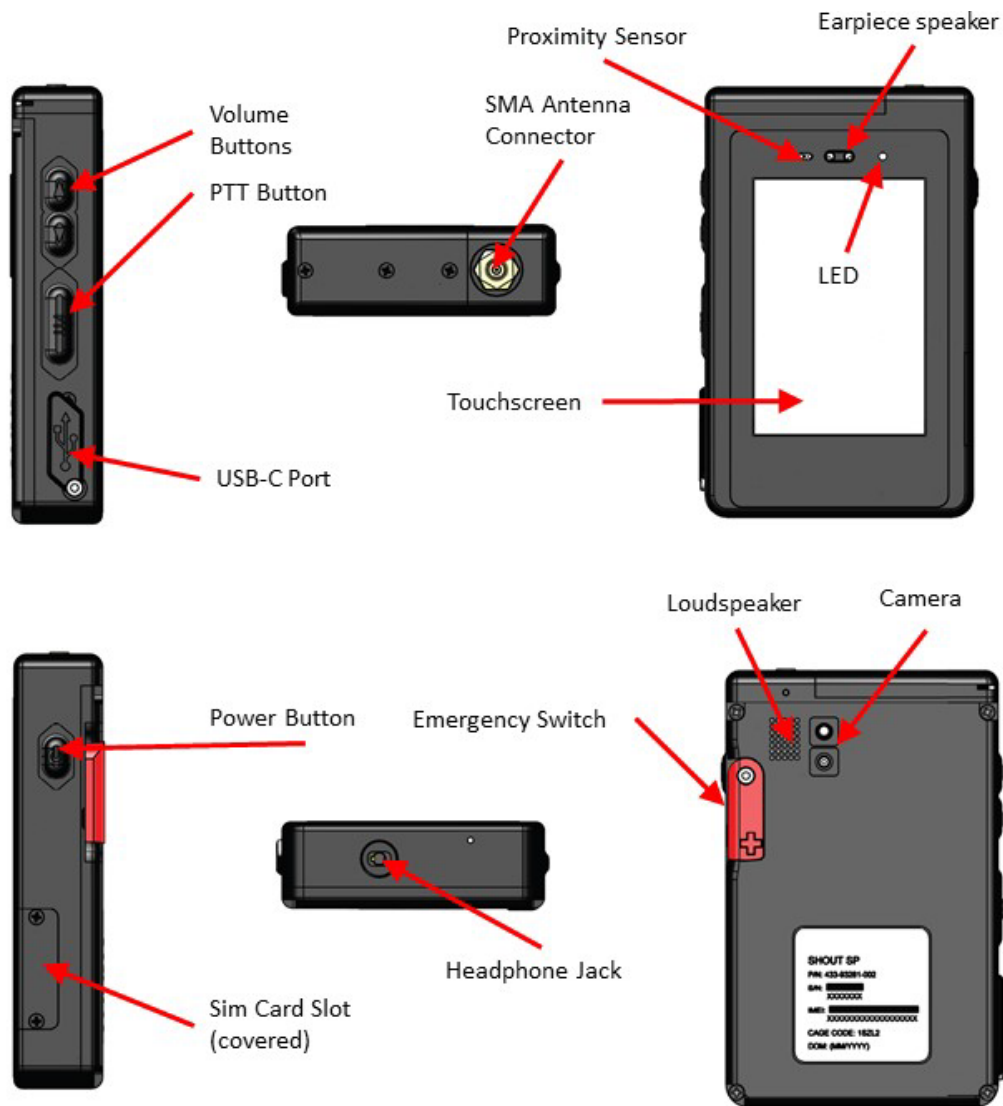
**IMPORTANT:** Do not disassemble the SHOUT sp for repair or services. The warranty is voided if the SHOUT sp is disassembled. Return it to NAL Research for service. Contact NAL

Research Tech Support by dialing 888 SHOUT NR (888-746-8867) or emailing [support@nalresearch.com](mailto:support@nalresearch.com).

## 2 USING THE SHOUT SP

### 2.1 DEVICE DESCRIPTION

The SHOUT sp user interface comprises a Touchscreen, a Power button, a Status LED, a guarded Emergency button, and a USB-C port. The Touchscreen allows easy access to the device features. The USB-C port is for battery charging, updating firmware and setting parameters with a configuration file. When enabled, the LED provides a quick reference of the status of the device.



*Figure 1: SHOUT sp Views and Features*

## 2.2 ACCESSORIES

### 2.2.1 SHOUT sp

The following accessories are included with the SHOUT sp.



AC Wall



USB-A to USB C

*Figure 2: SHOUT sp Accessories*

Manuals and software updates are available on the NAL Research website at <https://www.nalresearch.com/>.

### 2.2.2 SHOUT sp MOUNT KIT

The SHOUT sp Mount Kit securely holds the SHOUT sp to a vehicle's windshield, a hard flat surface, or a desk mount, while leaving the entire screen and control buttons accessible. It enables charging from a USB charger from either vehicular power or from an AC wall mount. It provides remote PTT capability through a handheld speaker-microphone, which amplifies PTT audio for use in noisy environments. The SHOUT sp Mount Kit supports telephony mode as well as PTT mode. The SHOUT sp Mount Kit is an accessory available on the NAL website.

The SHOUT sp Mount Kit consists of the following items:

- Suction cup mount or bolt-down mount for temporary or permanent installations
- Double Ball Articulating Arm
- Cradle with grips, speaker/microphone mounting bracket, and audio amplifier module
- Handheld Speaker-Microphone




*Figure 3: SHOUT sp Mount (Suction Cup)*

- USB-C car charging adapter/cable or AC Wall Mount charging adapter/ cable

For detail information on The SHOUT sp Mount Kit, refer to **Appendix F**.


## 2.3 CHARGING THE BATTERY

The SHOUT sp is shipped with its internal lithium-ion battery partially charged. Fully charge the SHOUT sp before use. There are two ways to charge the SHOUT sp. One is to use the supplied AC wall adapter. The other is to connect to a standard USB device. With the AC wall adapter, the charging time is approximately five hours. Charging time using a USB port depends on the type of USB port. USB 1.0 should be able to charge the SHOUT sp in about a day, assuming the port is capable of producing an output current of 100 mA. USB 2.0 can charge in about twelve hours, assuming the current output of 500 mA. NAL Research offers 12 V DC and 115 V AC chargers sold as separate items.


**WARNING!**

All batteries can cause property damage, injury or burns if a conductive material, such as jewelry or keys, touches exposed terminals. The material may complete an electrical circuit and become extremely hot. To protect against such unwanted current drain, exercise care in handling any charged battery, particularly when placing it inside your pocket, purse or other container with metal objects.

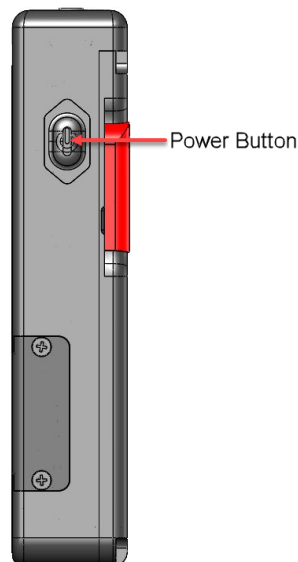
DO NOT disassemble the SHOUT sp to replace the battery. It should be returned to NAL Research for service. There is a risk of explosion if the battery is replaced with an incorrect type.

The SHOUT sp has a battery icon  at the top-right of its screen indicating the battery is being charged. The device can be safely operated and does not need to be turned off while charging but the charging cycle completes quicker when the device is shut down.

**IMPORTANT:** The SHOUT sp must be kept in environments between 0°C (32°F) and 45°C (113°F) when charging.

## 2.4 POWER ON/OFF & AWAKEN, REBOOT

1. **Turn on** the SHOUT sp by pressing the **Power** button on the side of the chassis for approximately 2 to 3 seconds (see **Figure 4**).



*Figure 4: Power Button*

The initialization process is as follows:

- The LED rapidly blinks for 20 seconds and stops blinking for the next 10 seconds.
- The NAL splash screen displays signifying a successful boot.
- The *Android Home* screen opens.

2. Swipe up on the screen to access the device features.

NOTE: The device display can be configured to automatically sleep from 15 seconds to 30 minutes of inactivity through Android **Settings>Display >Sleep**.

3. **Awaken** the SHOUT sp by pressing the **Power** button for approximately 1 second.
4. **Turn off** the SHOUT sp completely with no tracking or text messaging at any time, by pressing the **Power** button for approximately 2 seconds and pressing the **Power Off** icon that displays on the screen.
5. **Reboot** the SHOUT sp by pressing the **Power** button for approximately 10 seconds.

## 2.5 TOUCHSCREEN

The SHOUT sp has a capacitive touchscreen. A capacitive touchscreen is not affected by dust or grease. The screen has high resolution and high response speed. It detects touch by fingers only. It does not detect input by a gloved hand.

## 2.6 BASIC NAVIGATION

1. Select app icons from the favorites bar on the bottom of the home page to access phone, SMS messaging, device apps, the NAL SHOUT App, or the PTT functionality.
2. Tap the **Back Arrow** button at the bottom of the display at any time to return to the previous screen.
3. Move icons to appear anywhere on the screen by pressing, holding and dragging them to their new destination. The new destinations can be either a new home screen page or the favorites bar at the bottom of the screen.



*Figure 5: Back Arrow Button*

## 2.7 NETWORK OPERATING CENTER (NOC)

The SHOUT sp contains an Iridium 9523 L-band transceiver module, which uses SBD format over the Iridium satellite network to send GPS reports and messages to a NOC. The NOC can also send messages and commands to a SHOUT sp. A NOC can be a sophisticated central monitoring center equipped with servers connected to high-speed networks or simply a computer or handheld mobile device connected to the Internet, an Iridium transceiver, or any wireless network. Regardless the form or transmission pathway, a NOC **IS REQUIRED** in order to receive SHOUT sp messages and GPS data. To access Iridium service, the SHOUT sp must first be provisioned by NAL Research for commercial use or DoD DISA EMSS office for official government use.

## 2.8 SERVER FOR TRACKER SOFTWARE

Upon request, NAL Research can provide Server for Trackers software allowing user installation on their NOCs for the retrieval of NAL Research's formatted GPS reports from the remote SHOUT sp. In addition, the program lets a NOC communicate with modems attached to

its serial ports, communicate with POP3/SMTP servers, communicate with Iridium SBD DirectIP servers, and/or act as a RUDICS server/client to support incoming and outgoing communications with the SHOUT sp. Under special cases, and with a signed Non-Disclosure Agreement (NDA), NAL Research will release our proprietary GPS report formats for developers to implement into their own tracking software.

## 2.9 NAL VUE

NAL Vue, from NAL Research, is a subscription-based NOC service which delivers maximum situational awareness to assist with timely and effective decision-making. As a device-agnostic system, NAL Vue integrates all of the user's global trackable assets into a single, secure, web-based platform. Supervisors can monitor device position, velocity and heading, and exchange messages with their team in the field. NAL Vue is a mature product operated on redundant servers at a Tier II data center.



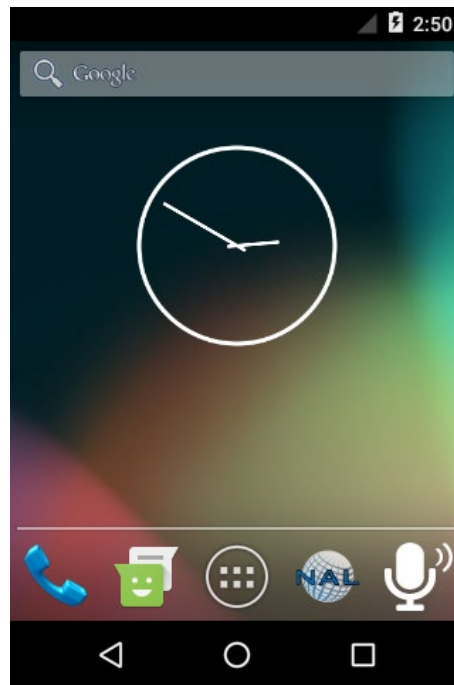
## 3 HOME SCREEN

The SHOUT sp uses the standard Android framework to render its display screens, providing a familiar user experience on a powerful industry-standard interface.

1. Power up the device.
2. Swipe up from the bottom of the screen to unlock the device.
3. Enter a PIN, if the device is set up with password protection.

**Note:** NAL Research ships the SHOUT sp without password protection.



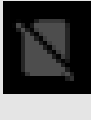




The *Home* screen appears. Device status symbols are shown at the top of the home screen. Some symbols will not appear until an event is initiated, such as sending or receiving a message.



*Figure 6: SHOUT sp Home Screen*

## 3.1 STATUS SYMBOLS

Table 2: Status Symbols

	<b>Battery Indicator (Lightning Bolt)</b>	Denotes the battery is being charged by an external power source.
	<b>Battery Indicator (gray and white)</b>	Indicates the remaining battery power level.
	<b>Missing Sim Card Indicator</b>	Illustrates that a SIM card has not been inserted into the device. If the device has a SIM card inserted, then no symbol appears on the screen.
	<b>Wi-Fi Indicator</b>	Denotes Wi-Fi signal when the SHOUT sp is connected to a Wi-Fi network.
	<b>Network Indicator</b>	Indicates the Iridium transceiver's real-time signal strength. <i>Note: During transmission the antenna must have a clear view of the sky. The SHOUT sp cannot typically send messages or reports from inside a building.</i>
	<b>Clock</b>	The current time is displayed in formats set by the <b>Settings</b> → <b>Display</b> → <b>Time Zone</b> option. The choices are UTC or Android time zone. <b>NOTE:</b> The sp obtains UTC timing from the GPS constellation once it has acquired a valid GPS location.
	<b>PTT</b>	The PTT indicator is present when the SHOUT sp is in push-to-talk [PTT] mode. The icon is not present when the PTT app is not running and the device is in telephony mode.

## 3.2 FAVORITE ICONS

The bottom of *Home* screen has a favorites bar. Any of the application icons can be moved to the favorites bar by pressing, holding, and dragging them to the bar. A maximum of four (4) favorite icons are allowed.

## 4 QUICK START

Iridium airtime services must first be purchased from NAL Research, before the SHOUT sp can be used over the air. The SHOUT sp can make Iridium Satellite phone calls when there is either an active Iridium Global SIM card (commercial service) or DISA EMSS SIM card (DoD Service) inserted.

The user is encouraged to read the entire manual to learn how to operate the SHOUT sp as a messaging device. As a tracking device, the user can quickly set up the SHOUT sp with just a few simple steps shown below.

NOTE: In order to send text messages and tracking information with the SHOUT sp the device **MUST BE** properly provisioned to send the data to a Network Operations Center.

1. Turn on the SHOUT sp by pressing the **Power** button for 2 to 3 seconds.

The LED blinks rapidly for 10 seconds while the SHOUT sp initiates its boot sequence.

2. Press the **Power** button to wake the SHOUT sp and display the *Home* screen.
3. Swipe up to unlock the SHOUT sp. (Enter a PIN if required.)

4. Tap the **SHOUT** icon.



5. Tap the **Settings** icon.



6. Select **Tracking** in the settings list.

7. Scroll down and tap **Remote Message Format** in the *Tracking* list. This option sets the format of the messages that are sent from the SHOUT sp to the NOC.

8. Tap the desired remote message format to select it from the list.

9. Tap the **Back Arrow** button at the bottom of the display two times to return to the home screen.

10. Tap the **Tracking** icon.



11. Tap the **Report Rate** icon, and select **Tracking On**.



12. Enter the **Report Rate** in minutes.

13. Press the **Update** button to accept the changes.
14. The SHOUT sp is now in tracking mode and ready to send position reports. No further action is required. The unit automatically goes to sleep in between reports.

## 5 SHOUT SP DISPLAY

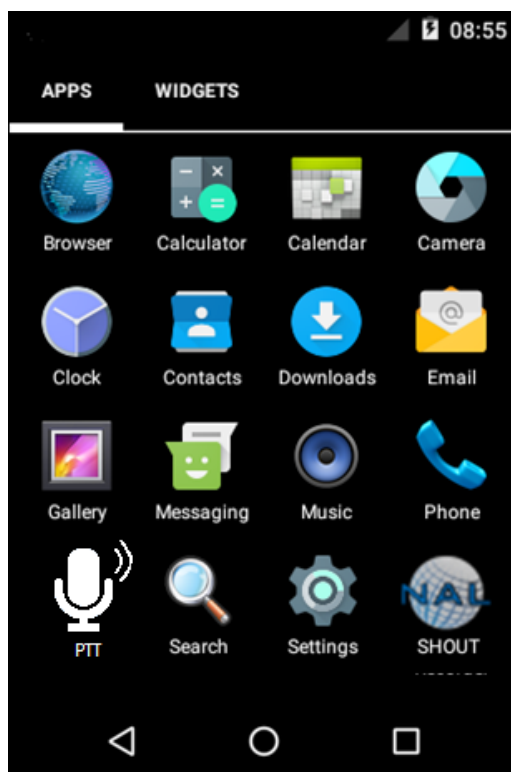
### 5.1 HOME SCREEN

Access the Android preloaded apps screen by pressing the **Applications menu** icon (highlighted with orange in **Figure 7**) located in the favorites bar at the bottom of the SHOUT sp home screen.



*Figure 7: Android App Screen Button*

**Figure 8** contains all of the default apps available on the SHOUT sp, as well as any apps loaded by the user.



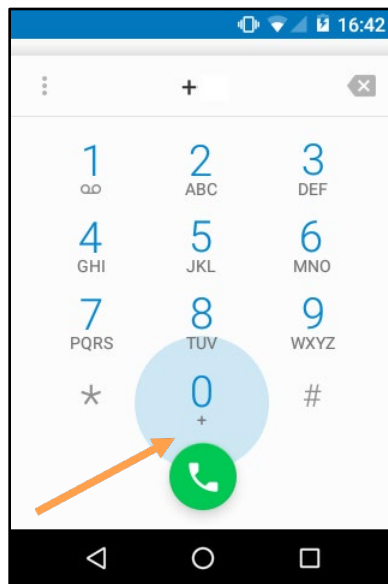
*Figure 8: Preloaded Android Apps*

## 6 MAKING A PHONE CALL

To make a phone call, an activated SIM card must be installed in the SHOUT sp. If a SIM card is not installed, contact NAL Research Customer Support by dialing 888-SHOUT-NR (888-746-8867), or emailing [support@nalresearch.com](mailto:support@nalresearch.com).

### 6.1 FROM THE ANDROID KEYPAD

Users can make a phone call by tapping the phone icon on the Android app screen which then displays the Android phone keypad. To make a call from the SHOUT sp, first dial the country code, then the area code, and then the phone number. (Country code for the US is +1 or 001). To start a call with a '+' sign, press and hold the '0' key on the Android phone keypad, as seen in **Figure 9: Android Phone Keypad** below. The plus (+) sign displays in the phone number field. When the complete phone number has been entered, tap the call icon to dial the phone, as shown in **Figure 11** (on the following page).



*Figure 9: Android Phone Keypad*

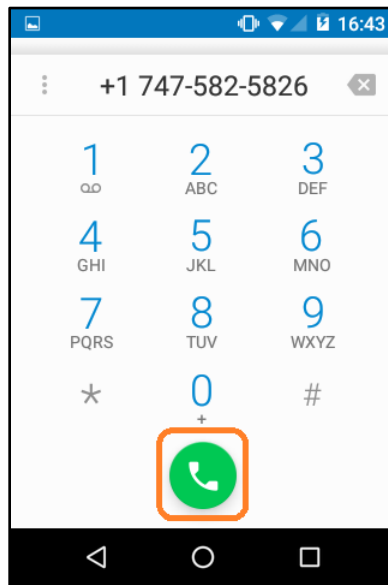


Figure 10: Call Icon

## 6.2 FROM ANDROID CONTACTS

1. Tap the **Contacts** icon on the Android app screen to open the *Contacts* screen, as seen without any contacts in **Figure 11**.
2. Press **Create a New Contact** to open the *Add new contact* screen, as shown in **Figure 12**. (If contacts already exist in the unit, tapping the *Contacts* icon will open the *Contacts* list screen.)

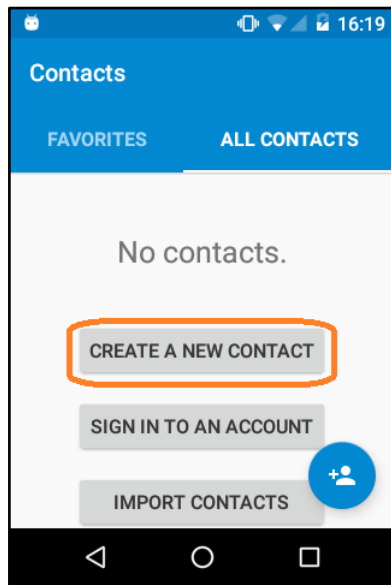


Figure 11: Create a New Contact

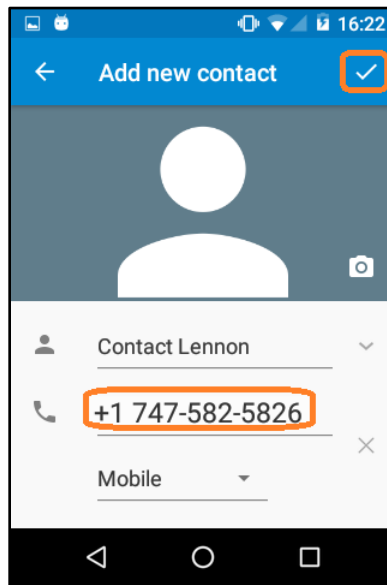


Figure 12: Contact Info

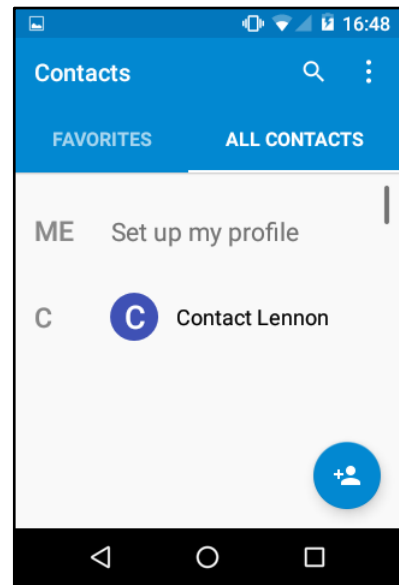


Figure 13: Contacts List

3. Enter the contact name, phone number and other details as needed.
 

**Tip:** To start the contact's phone number with a '+' sign, press and hold the '0' key on the Android phone keypad.
4. When finished entering contact information, press the check mark, as seen at the top-right of **Figure 12**, to save the contact. **Figure 13** displays the entered contact.
5. To initiate a call from the contact list, tap the desired contact name in the list (see **Figure 14**). This displays the contact's information, as seen in **Figure 15**.
6. Tap the **phone** icon on the left to call the contact, or tap the text bubble icon on the right to initiate an Iridium SMS text message to the contact.



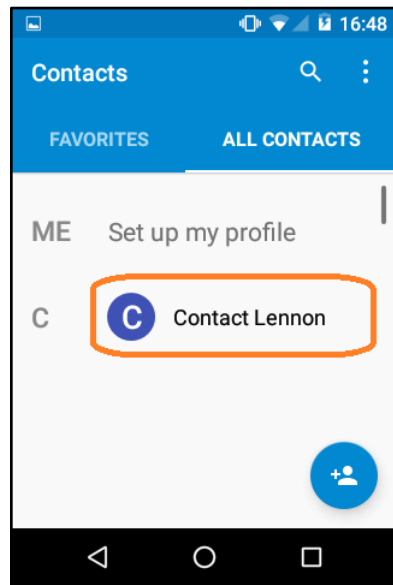


Figure 14: Create List

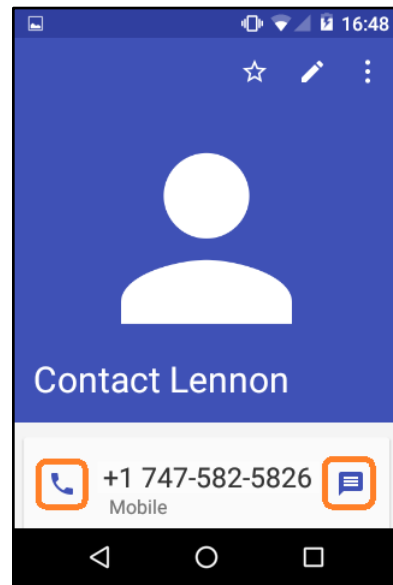


Figure 15: Contact Information

## 7 IRIDIUM SHORT MESSAGE SERVICE (SMS)

Iridium SMS is incorporated in the SHOUT sp through the Android Messaging App. Messages can be sent between two SHOUT sp devices, or from a SHOUT sp to another Iridium telephony device, or from a SHOUT sp to a cell phone. When an Iridium SMS message is passed between two Iridium based telephony devices the message is carried solely over the Iridium architecture. If SMS messages are sent to a cell phone they are routed through Iridium's gateway and then forwarded through the commercial carrier's network (Verizon, AT&T, etc.).

**NOTE:** The SHOUT sp does not incorporate cellular technology. It uses the Iridium satellite constellation only.

However, the Android Messaging App behaves just as it does in cellular devices. Messages may be sent by selecting a contact from the Android contact list, or the messaging bubble from within a contact as shown above in **Figure 13** above, or the phone number may be manually entered in the 'to' line of the message using the same naming convention for phone numbers required to make phone calls, +1 (555) 555-5555 for a commercial number in the U. S. or +1 8816 XXXX YYYY for an Iridium phone device.

## 8 NAL SHOUT APP

The main menu of the SHOUT app (**Figure 14**) provides access to the four (4) submenus: **Texting, Tracking, Utilities, and Settings**. At the bottom of the screen is text indicating the application status. If it has successfully connected to the SHOUT sp, the text will read “*Connected*”. When not connected, the text will read either “*Not Connected*” or “*Incompatible with SHOUT sp + <version number>*”. If *Not Connected* is displayed conducting a power cycle on the unit should remedy the issue. The *Incompatible* message indicates that there is a mismatch between the app and device software versions. Updating both to the latest available software will correct the issue.

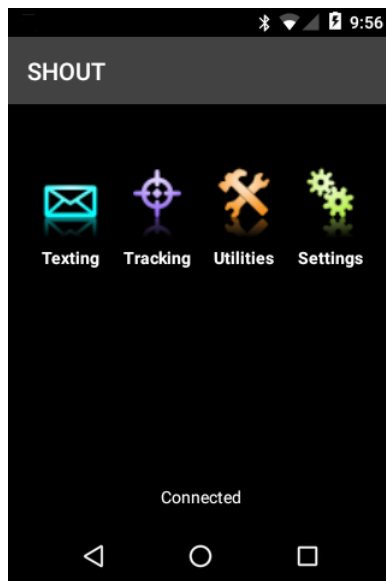


Figure 16: Tracking App Main Menu

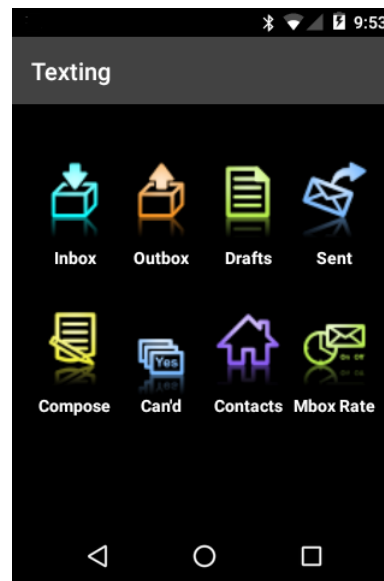


Figure 17: Texting Menu

### 8.1 SHORT BURST DATA (SBD) TEXTING MENU

Texting capability through the SHOUT app relies upon Iridium’s SBD service. All SBD message traffic (texts and location information) is routed to a NOC, such as NAL Vue by NAL Research. In order to send or receive SBD text messages, through either the commercial or DoD Iridium gateways, the following steps must happen first:

1. SBD service must be activated on the SHOUT sp.
2. The NOC server IP address must be added to the device record in Iridium’s SPNet.

- If using NAL Vue, the device must be linked to the appropriate Address Book Group.

Once a device has been properly provisioned users can send text messages to the NOC, an email address (es), or another SHOUT sp unit by routing the message through the NOC server.

### 8.1.1 TEXTING



The *Texting* menu allows the user to check the mailbox for incoming, outgoing and sent messages, compose new messages, view draft messages which have been saved, add and view canned text messages and contacts, and set up an automatic mailbox check rate.

### 8.1.2 INBOX



The SHOUT sp Inbox folder (**Figure 18**) displays all received messages. The newest message appears at the top of the list. Tapping a message shows the message details with the complete text of the message and a delete button.

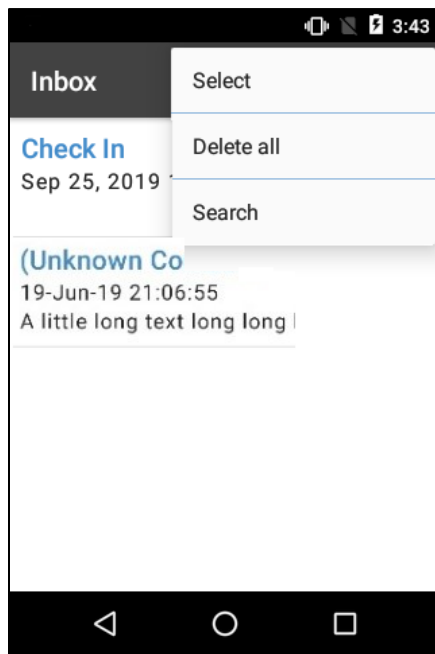


Figure 18: Inbox

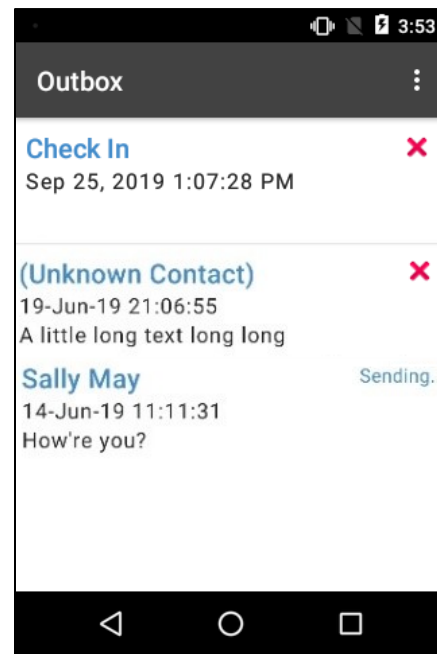


Figure 19: Outbox

### 8.1.3 OUTBOX



The SHOUT sp outbox folder (**Figure 19**) displays messages in the process of being sent and messages which have failed to send. They are sorted in the order of priority, and then by the oldest to the newest messages. Messages are held in this folder for a specified

period of time set by the user. The user sets the interval which the device sends and checks for new incoming messages, see 16.1.9 Mbox Rate.

A message *in the process* of being sent has "Sending..." on the right side of the list entry. A message that has *failed* to send is marked with a red X symbol. For each message queued in the outbox waiting to be sent, the device has a two-minute window to transmit. After which time, the message will be dequeued and marked with the red X to avoid draining the battery.

Tapping a message shows the message details with the complete text of the message and a delete button. Tapping the red X gives the option to delete or retry. Failed messages remain in the outbox. If the user decides to retry a failed message, and if the failed message is successfully retransmitted, the SHOUT sp automatically attempts to retry all other failed messages in the outbox.

Messages in the outbox are sent in order of priority. Within priority categories, the oldest messages are sent first.

Category 1 (highest priority):

- Callout
- Cancel Emergency

Category 2:

- Check-In
- Queued Tracking Report

Category 3:

- Motion Start/End Report
- Statistics Report
- Test Report

Category 4 (lowest priority):

- Remote Update Response
- Poll Report
- Text Message
- Waypoint

## 8.1.4 DRAFTS

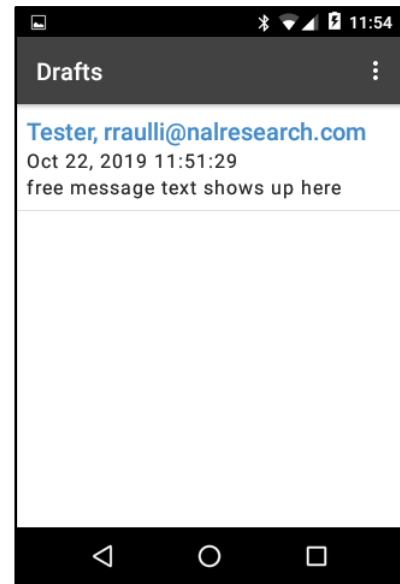


The *Drafts* folder (**Figure 20**) contains draft messages saved under the *Compose* function. The newest messages are shown at the top of the list. Selecting a draft message takes the user back to the *Compose* screen.

## 8.1.5 SENT



The *Sent* screen contains messages successfully sent by the Iridium modem. Selecting a message shows the message details screen with the complete text of the message and a delete button. Messages are shown in the *Sent* screen with the newest message displayed at the top of the list.



*Figure 20: Drafts*

## 8.1.6 COMPOSE

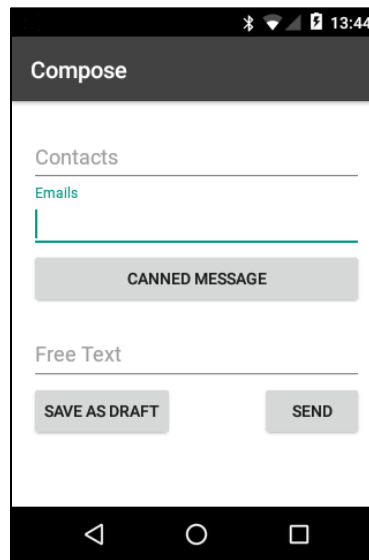


The *Compose* screen allows the user to enter, edit and send messages to: (1) a NOC server, (2) a contact saved in the SHOUT App, (3) a user-entered email address.

**NOTE** – To successfully send messages over the SHOUT App, both the device and NOC server must be provisioned properly.

### 8.1.6.1 COMPOSE EMAIL

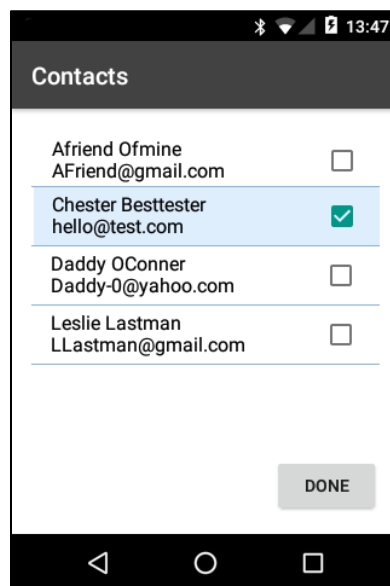
Tap the *Compose* icon. The *Compose* screen appears with three text entry fields and a *Canned Message* button, as shown in **Figure 21**.



*Figure 21: Empty Compose Screen*

### 8.1.6.2 SELECT MESSAGE RECIPIENTS FROM CONTACTS LIST

1. Tap the **Contacts** field. Contacts which have been entered in the SHOUT App appear in alphabetical order, as shown in **Figure 22**.

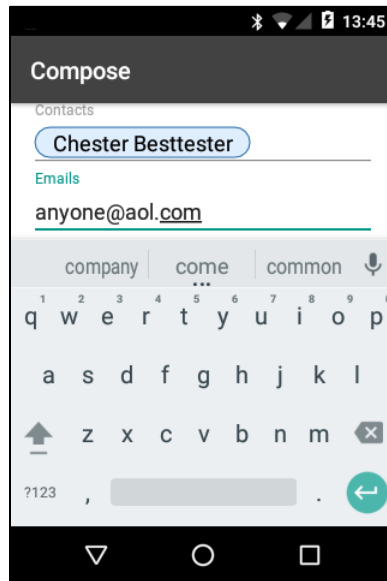


*Figure 22: Compose and Select Contact Option*

2. Select a single contact or multiple contacts from the list. Remove a contact by going back to the *Contacts* screen and clearing the check box to the right of the contact.
3. Tap **DONE** to accept.

### 8.1.6.3 ENTER MESSAGE RECIPIENTS' EMAIL ADDRESS(ES)

1. Tap the **Emails** field. A keyboard appears, as shown in **Figure 23**.



*Figure 23: Compose and Enter Email Option*

2. Enter the email address(es).

When sending messages between two SHOUT sp devices and using NAL Vue as the NOC, the naming convention is the IMEI number followed by @NALVUE.com. (i.e. 300425060811660@NALVUE.com).

3. In order to utilize this functionality, the device IMEI's must be added the into the organization's NALVUE account.
  - Multiple email addresses can be entered separated by a semicolon.
  - The list of email addresses, including semicolons, may not exceed 255 characters.
  - Email addresses and free-text messages share the same memory space with a maximum allowable length of 309 characters.
  - Long email addresses or multiple email addresses will reduce the number of characters available for the free-text message.

### 8.1.6.4 SEND A CANNED/FREE-TEXT MESSAGE

1. Press the **Canned Message** button to open a canned message selection screen. The canned messages appear in the index order.



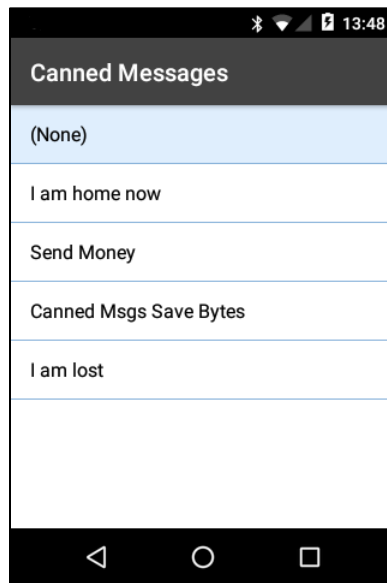


Figure 24: Canned Messages List

2. Tap a **Canned Message** to choose the message.

The message text is shown on the *Compose* screen between the *Canned Message* button and the *Free Text* label.

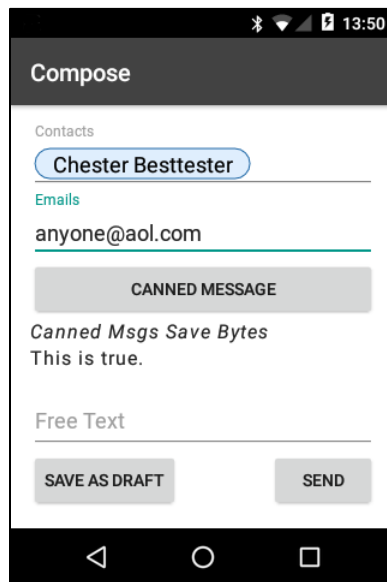
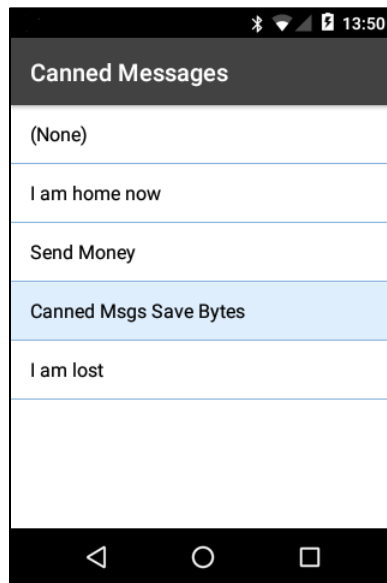


Figure 25: Compose with Canned Message

3. Press the **Canned Message** button again to return to the *Canned Messages* screen and remove the canned message, or select a different one.



*Figure 26: Select Different Canned Message*

4. Optionally, select the **Free Text** field to bring up the on-screen keyboard for text message entry.
5. After selecting a canned message and/or composing a free-text message, either select **Send** the message or **Save as Draft**.

### 8.1.7 CAN'D MSGS



Tap the **Can'd Msgs** icon to view the canned messages. **Figure 27** below illustrates a *Canned Messages* screen with four (4) canned messages. Select a canned message to view or edit by tapping the message itself. Reorder canned messages by dragging the hamburger icon to the right of each item, or press **ADD** to add a new canned message, as shown in **Figure 28**.

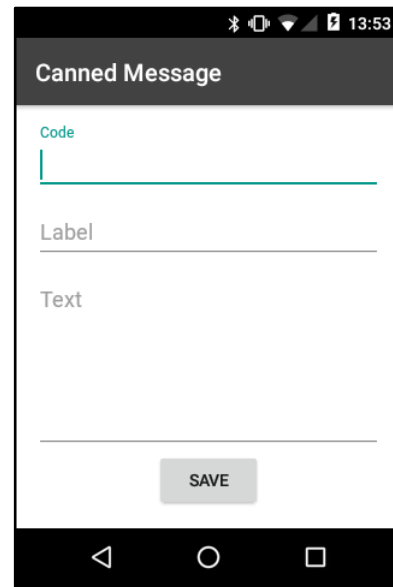
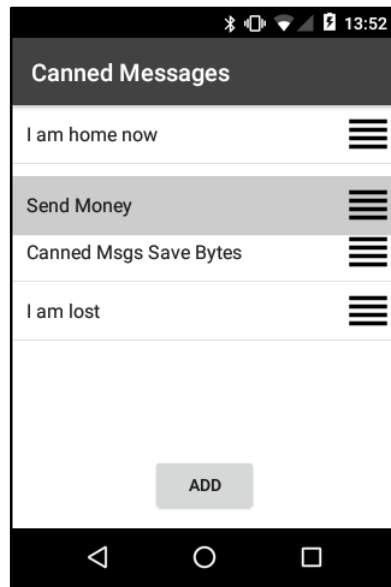


Figure 27: Reordering Canned Messages      Figure 28: New Canned Message

When adding a new canned message, enter a 2-digit code (30-99) in the *Code* field, a message label in the *Label* field and the message text in the *Text* field. Canned messages are transmitted using just the canned message code and the message text. To ensure the recipient understands the message, the canned message code should be synchronized between the sender and recipient.

### 8.1.8 CONTACTS



Tap the **Contacts** icon to view the contacts. **Figure 29** below illustrates a *Contacts* screen with four contacts. Select a contact to view or edit by tapping the contact itself, as shown in **Figure 30**. Contacts are displayed in alphabetical order. Create a new contact by pressing the **ADD** button. Information about each contact is contained in six fields: *Code*, *Name*, *Group*, *Email*, *Phone*, and *Location*, as seen in **Figure 31**.

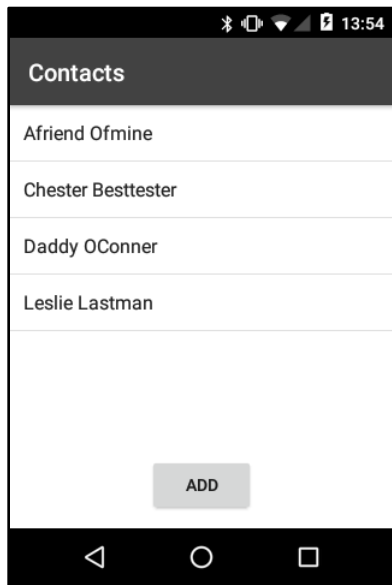


Figure 29: Contact List Display

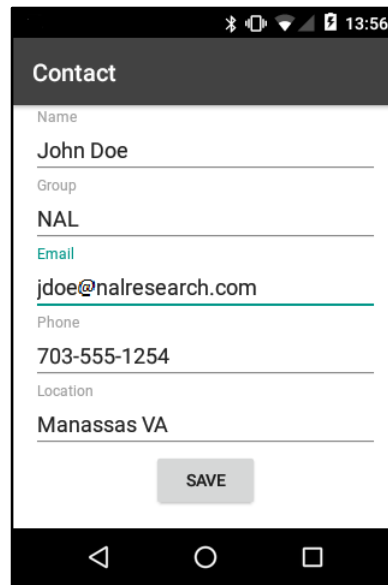


Figure 30: Edit Contact

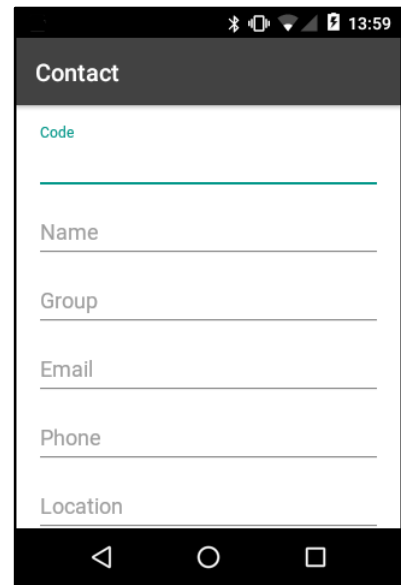


Figure 31: New Contact

The *Code* field is transmitted to the NOC for routing the message to the destination. Therefore, the *Code* value should be synchronized with the NOC so that messages are routed correctly.

**Note:** When PECOS text messaging format is used, the phone number field for each contact should contain the destination IMEI number.

**Note:** Depending upon some app settings, the user may need to scroll down to see the ADD, SAVE and DELETE buttons.

### 8.1.9 MBOX RATE



Use the Mailbox Check to enable or disable mailbox checking. Use the Mailbox Check Rate to schedule

mailbox checks. Enter a Mailbox Check Rate in minutes (between 0–10080) in the *minutes* field. The selected rate triggers the time for the app to initiate a check of the mailbox. This function only works when connected to the Iridium network.

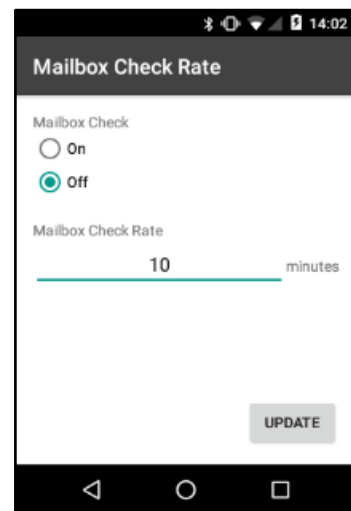


Figure 32: Mailbox Check Rate

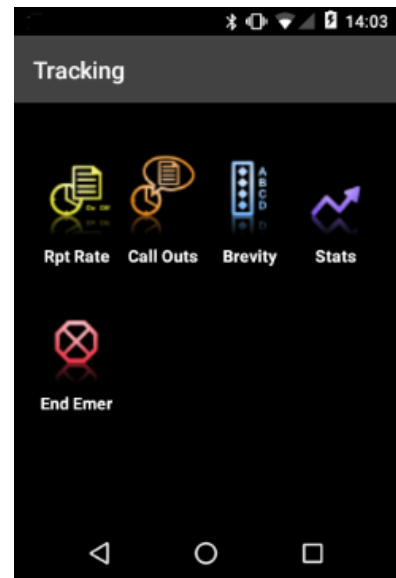
## 8.2 TRACKING MENU

### 8.2.1 TRACKING



The *Tracking* menu for the SHOUT app is shown in

**Figure 33.** There are several different functions used to interact with tracking. The *Rpt Rate* (Report Rate) screen is used to enable tracking and to set the report rate (time between tracking reports). The *Call Out* function requires the user to load parameters from a configuration file with preconfigured times to send Call Out messages each day. *Brevity* allows the operator to select from up to 16 different predefined messages which can be sent to the NOC (or other sp devices??). *Stats* displays statistics about tracking data for the device and *End Emer* allows the operator to cancel the emergency beacon when it is no longer needed after having activated it.



*Figure 33: Tracking Menu*

### 8.2.2 RPT RATE



Rpt Rate allows the operator to enable tracking reports and set the interval between reports. The *On/Off* radio buttons are used to enable/disable tracking mode. When tracking is On (**Figure 34**) the LED on the SHOUT sp blinks green in 1-second intervals. The device immediately turns on the GPS receiver to acquire a GPS fix and then attempts to transmit a position report. The next position report is sent automatically based on the reporting rate.

The SHOUT sp will sit idle between reports to preserve battery life. Because the SHOUT sp uses the Iridium network, when waking up to transmit a location report, the device must have an unobstructed view of the sky otherwise, it will fail to send. For example, if at the time a report is to be sent the operator is indoors the report will fail to be transmitted. By default, a failed report will not be re-sent. That setting can be changed in the Tracking Profile settings which is discussed later in this manual.

The entire reporting duration can take up to two minutes, depending on the Iridium constellation and the validity of the GPS data. A Report Rate (*Time Between Reports*) set to

more than two hours (120 minutes) requires more time for the GPS receiver to acquire position information. As a result, the device will consume more battery power and the total number of reports will be reduced.

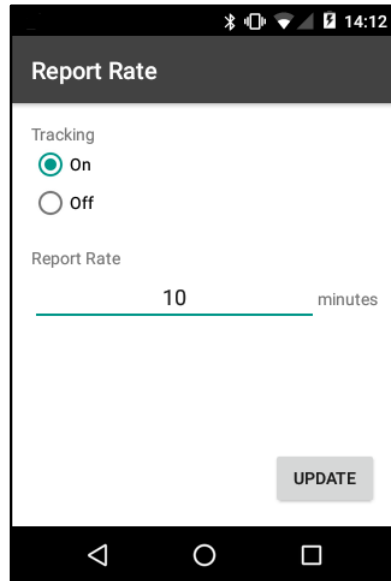


Figure 34: Reporting Rate Enabled

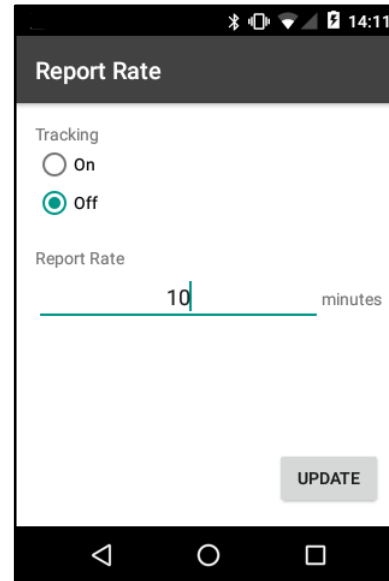


Figure 35: Reporting Rate Disabled

Remote message format can be set under the *Settings* menu, within the *Tracking* option labeled *Remote Message Format*. For more information on reporting formats, see the **Settings Menu** section on **page 53** of this manual.

Encryption is also available for any of the supported formats. With encryption enabled, the minimum bytes for 10-byte format increase to a 16-byte format. For 30-byte format, the minimum byte count is increased to 32. Encryption options are maintained in the **Settings Menu**. (See **page 53** of this manual.)

### 8.2.3 CALL OUTS



*Call Outs* allows the user to send scheduled daily tracking report at a defined UTC time. Scheduled times are entered via a configuration file and are listed on the *Call Outs* screen.

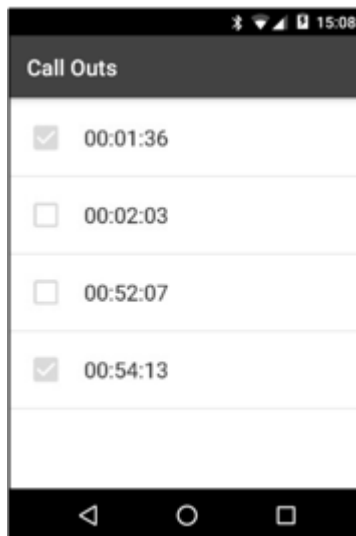


Figure 36: Call Outs

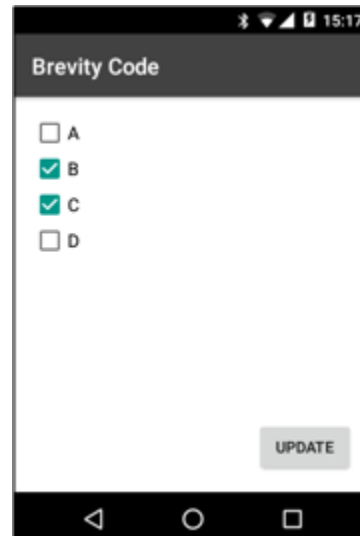


Figure 37: Brevity Code

## 8.2.4 BREVITY



The brevity code is part of the PECOS format. The device will ignore the brevity code settings if PECOS format is not enabled and not selected. With PECOS enabled, the user has the option to select any one of sixteen brevity codes (0000 through 1111) to be included in the PMS tracking reports. These codes are represented by A, B, C and D; select specific brevity codes via check boxes. See the **Brevity Code** section of the **Settings Menu** on **page 66** of this manual for more information.

## 8.2.5 STATS



The *Statistics* screen provides details regarding all tracking data since the *CLEAR STATS* button was pressed through the last report sent, as seen in **Figure 38**. The *Stats* screen has a countdown *TIME TO NEXT* report timer at the top that displays *Off* when tracking is disabled. The *Statistics* screen displays the last successful report sent by tracking. The bottom section of the *Statistics* screen displays tracking stats since the last time the *CLEAR STATS* button was pressed.

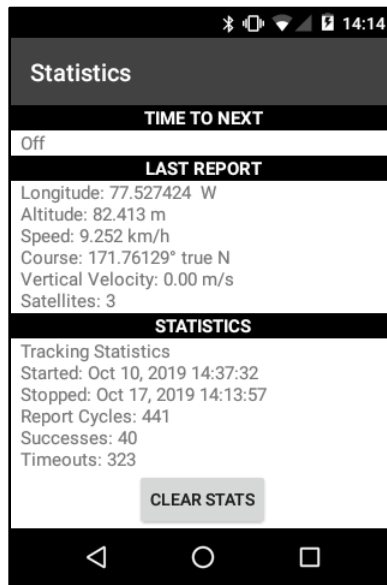


Figure 38: Statistics

**Note:** Check-In, Way Point, free-text and canned messages are not considered as reports and, therefore, will not be displayed even if a message was sent successfully.

## 8.2.6 END EMER



Users activate *Emergency* mode by rotating the emergency button cover (see **Figure 1**) outward and pressing the exposed *Emergency* button. To cancel the *Emergency* mode, they must perform one of the two steps below.

Deactivate Emergency Mode

Method 1: Tap the **End Emer** (End Emergency) icon. A prompt requiring the user to confirm ending the emergency displays, as seen in **Figure 39**. The *End Emergency* message is then queued in the outbox to be transmitted.

Method 2: Press and hold the **Emergency** button for two (2) seconds.



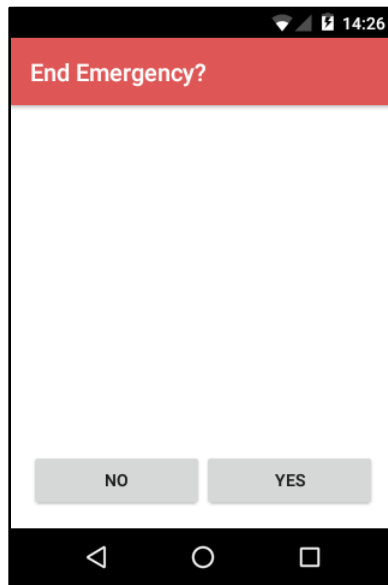


Figure 39: End Emergency

When the End Emergency has been issued, the LED switches from a solid green to its previous state. It either blinks in 1-second intervals if tracking was enabled, or is dark if tracking is turned off.

## 8.2.7 UTILITIES MENU



The *Utilities* menu provides five (5) functions used to check for proper hardware operation and network setup. These utilities are useful when trying to troubleshoot certain problems with the device.

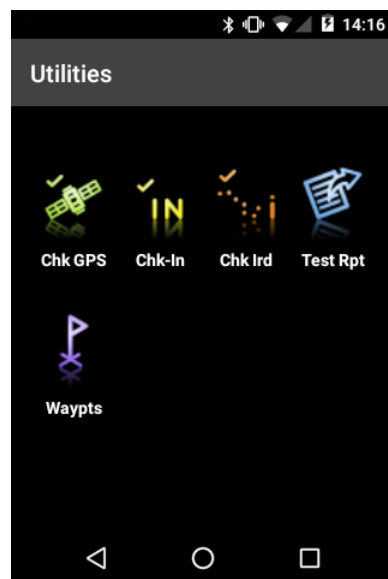


Figure 40: Utilities Menu

## 8.2.8 CHK GPS



The *Chk GPS* (Check GPS) function forces the device to turn on its GPS receiver and to continuously update and display GPS data in real-time. The GPS receiver remains on until the user leaves this screen by tapping the *Back* arrow. Use the *RESET EPHEMERIS* button to erase the saved ephemeris in its memory, download a new set of ephemeris data, and then reboot the GPS receiver. The rebooting of the GPS receiver initiates a cold start, which takes approximately 35 seconds in order to acquire the GPS position. Be careful not to deplete the battery power by staying on this option for too long.

The *Check GPS* function is a good indicator of whether or not the GPS receiver has sufficient signal to initiate a Way Point or Test Report when located in a challenging environment; e.g., in dense foliage or around urban settings with tall buildings. Satellites are monitored in real-time to make sure there are at least 4 in range, at which point, it is certain that a 3-D fix can be obtained. A higher count of satellites generally results in a better position. The user can then go back to the *Utilities* menu to send a test report.

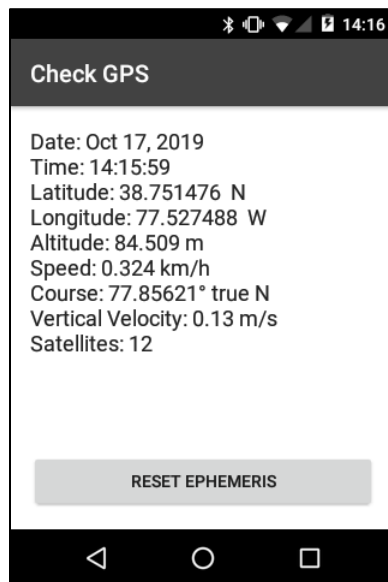


Figure 41: Check GPS

## 8.2.9 CHK-IN



The *Chk-In* (Check-In) function allows the user to send a quick message. When the **Check-In? YES** button is pressed (as in **Figure 42**) the device sends out a reserved canned message code representing a Chk-In message. If the *Include GPS* option is enabled as a setting of texting, the GPS location will be attached to the Chk-In message. See page 60 of this manual for more details about including GPS in a message.

The *Outbox* screen is displayed for the user to view or cancel the message. Tap the **Back arrow** to return to the *Utilities* menu.

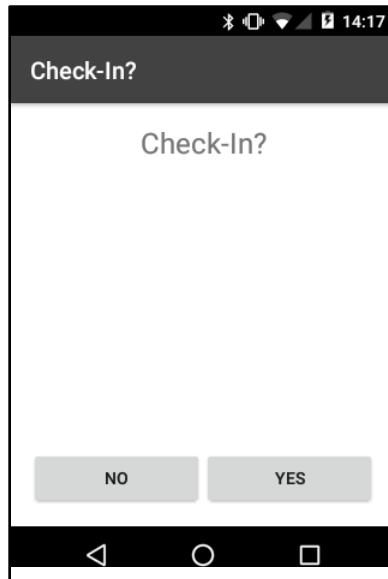


Figure 42: Check-In

**Note:** Chk-In messages with GPS locations take longer to complete since the device has to acquire a GPS fix first.

### 8.2.10 CHK IRIDIUM



The *Chk Iridium* function forces the device to turn on its Iridium transceiver and continuously update and display signal strength in real-time. The Iridium transceiver remains on until the user leaves this screen by tapping the back arrow. Be careful not to deplete the battery power by staying on this option for too long.

### 8.2.11 TEST RPT



When the *Test Rpt* (Test Report) function is selected, the device immediately turns the GPS receiver on to update its location data. The location information is continuously updated and displayed in real-time whether there is a valid fix or not. Similar to the Chk GPS function, Horizontal Accuracy (HACC) can be monitored to see if a valid fix is possible. Once a valid fix is obtained, the GPS receiver is turned off and the most recent 3-D fix information is displayed on the screen. This information will be sent to a NOC server in a position report message referred to as a test report by pressing **SEND**. A test report has the same format as a regular position report and is treated as such by a NOC. Sending a test report will not disrupt or change the tracking reporting rate.

The *Test Rpt* function is a good diagnostic tool used to ensure proper operation of the GPS receiver, the Iridium transceiver, and reception at the NOC. It can also be used to manage battery life by turning off tracking mode and strategically sending on-demand location reports. This is considered *Manual Tracking Mode*.



Figure 43: Check Iridium

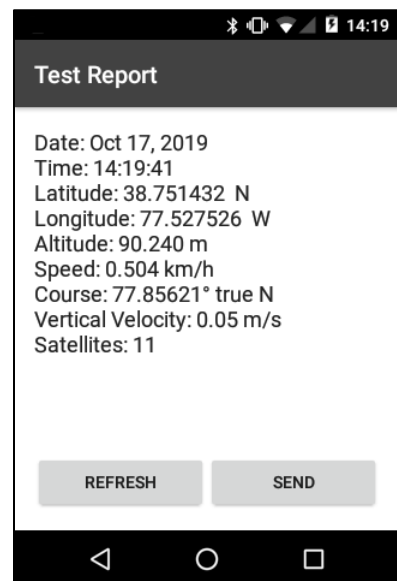


Figure 44: Test Report

After pressing the *SEND* button, The *Outbox* screen is displayed to view or cancel the message. Tap the back arrow to return to the *Utilities* menu.

## 8.2.12 WAYPTS



The *Waypts* (Waypoints) submenu is used to acquire, view, save, delete, delete all, or send a waypoint to a NOC. The SHOUT sp can save thousands of waypoints in memory.

A Waypoint is a GPS location that the user wants to identify and mark with a specific label name for future reference. When the *NEW* button is pressed, the device immediately turns on the GPS receiver to acquire a fix. The user then has the following options as seen in **Figure 46**: go back without further action, *REFRESH* the GPS fix, enter a label, or save the waypoint by pressing the *ADD* button.

Waypoint labels may be left blank and can be modified at any time. Waypoints are saved into the device's nonvolatile memory for later retrieval. After saving a waypoint, the user can select it from the list and send it to a NOC server by pressing the *SEND* button. The server differentiates a waypoint report from normal tracking report by their Short Code of '6'.

After pressing the **SEND** button, The *Outbox* screen is displayed. View or delete the message. Tap the **back arrow** to return to the *Waypoints* screen.

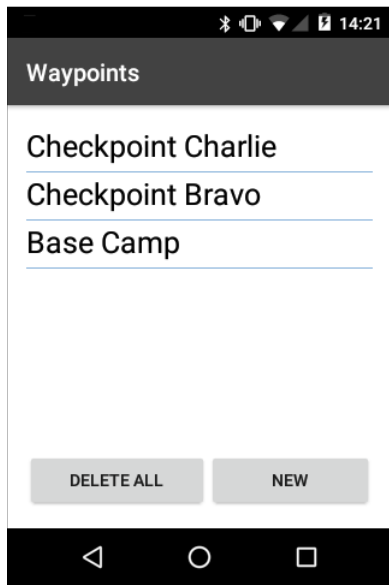


Figure 45: Waypoints

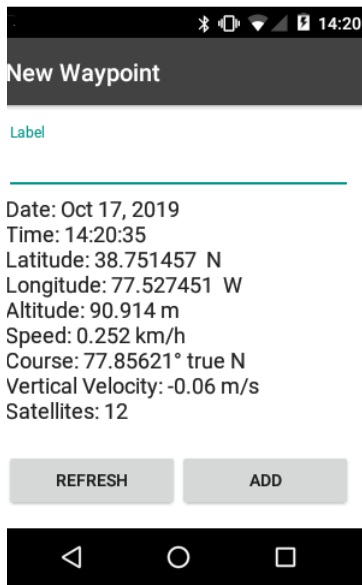


Figure 46: New Waypoint

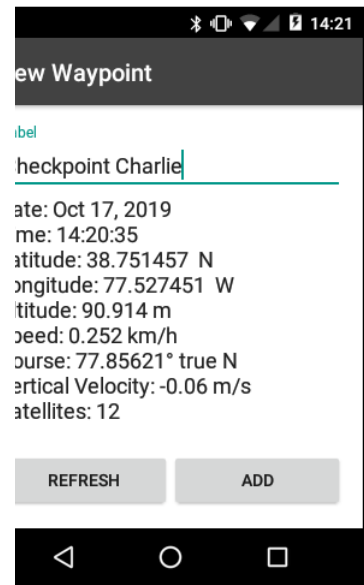


Figure 47: Waypoint Selected

## 8.3 SETTINGS MENU

### 8.3.1 SETTINGS



The *Settings* menu allows you to view and customize the SHOUT app settings.

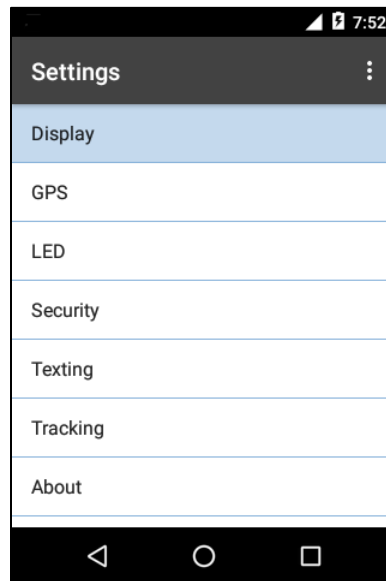


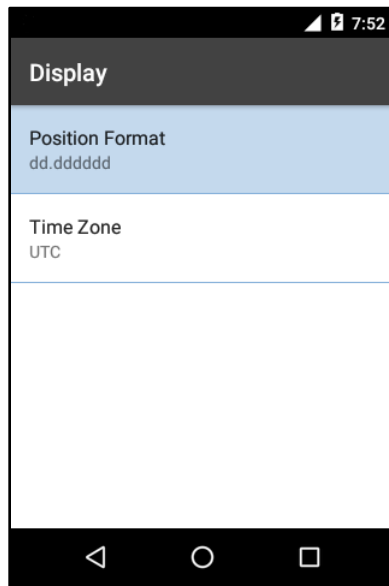
Figure 48: Settings

## 8.3.2 DISPLAY

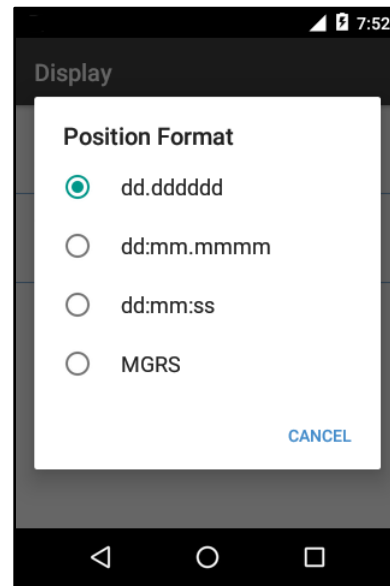
The *Display* settings submenu allows configuration of the user's display preferences.

### 8.3.2.1 POSITION FORMAT

Choose one of four (4) different GPS display formats when the app outputs GPS data (see **Figure 50**).



*Figure 49: Position Format*



*Figure 50: Display Menu*

### 8.3.2.2 TIME ZONE

Determine the display of the local time zone, measured in hours offset from UTC, populated by the GPS input, or the Android device's time zone set manually by the user (see **Figure 51**).

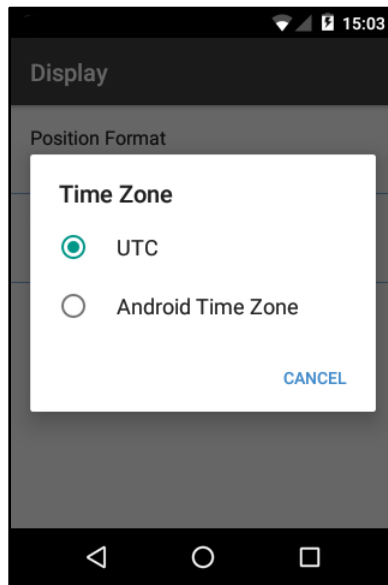


Figure 51: Time Zone

### 8.3.3 GPS

The GPS settings submenu provides access to the *Invalid Course Value* and *Position Model* options.

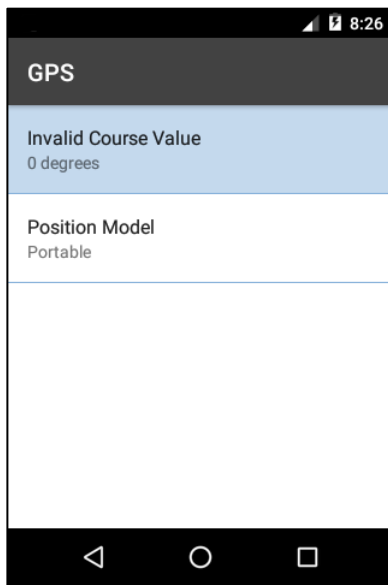


Figure 52: GPS

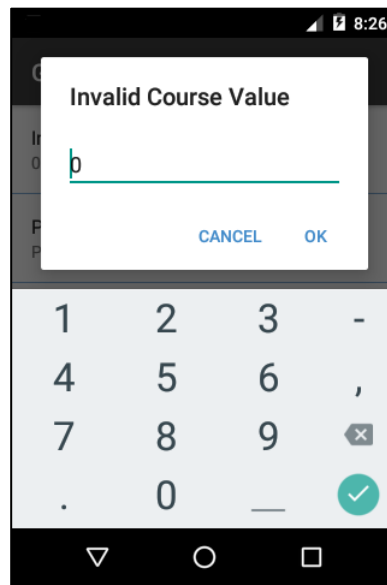


Figure 53: Invalid Course Value

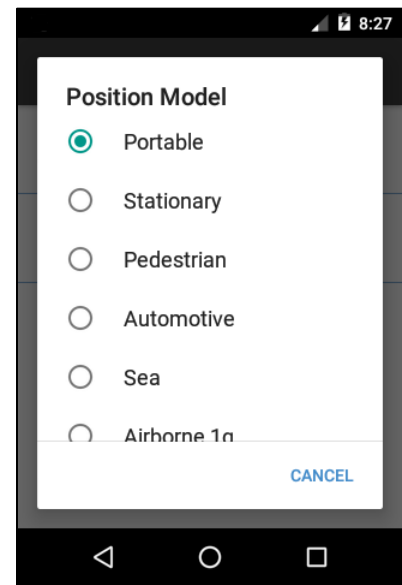


Figure 54: Position Model

#### 8.3.3.1 INVALID COURSE VALUE

This value is sent in GPS reports to indicate an invalid course when the GPS receiver is unable to determine the course. The value should be left at the default of zero unless a different value is required for server compatibility.

### 8.3.3.2 POSITION MODEL

This model is used to formulate the static and dynamic characteristics of the GPS receiver to optimize GPS location performance. By default, the *Portable* model is used; this is suitable for most applications. However, for those requiring functionality at high altitudes, speeds, or accelerations, an alternate model should be selected.

See **Table 3: Position Model Reference Table** for details.

*Table 3: Position Model Reference Table*

	Use Case	Max ALT	Max Velocity	Max Vert. Velocity	Sanity Check	Max Pos. Deviation
<b>Portable (default setting)</b>	Suitable for most situations. For applications with low accelerations.	12 km	310 m/sec	50 m/sec	ALT & Velocity	Medium
<b>Stationary</b>	Antenna must be stationary, or other stationary applications. Velocity is constrained to 0 m/s. Zero dynamics assumed.	9 km	0 m/sec	6 m/sec	ALT & Velocity	Small
<b>Pedestrian</b>	Low acceleration and low speed, as a pedestrian would move.	9 km	30 m/sec	20 m/sec	ALT & Velocity	Small
<b>Automotive</b>	Dynamics of a passenger car. Low vertical acceleration.	6 km	84 m/sec	15 m/sec	ALT & Velocity	Medium
<b>Sea</b>	Applications at sea, assuming zero vertical velocity.	500 m	25 m/sec	5 m/sec	ALT & Velocity	Medium
<b>Airborne 1g</b>	Higher dynamic range than a car and higher vertical accelerations. No 2-D position fixes supported.	50 km	100 m/sec	100 m/sec	Altitude	Large

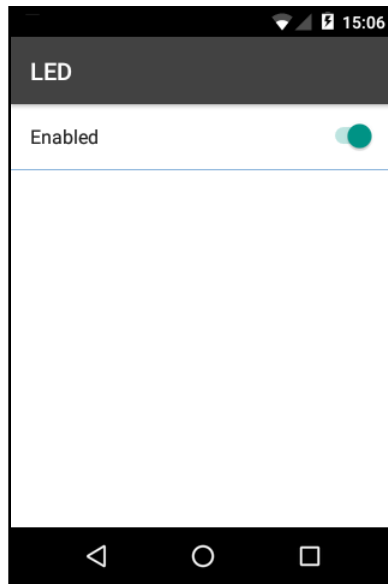


*Table 3: Position Model Reference Table*

	Use Case	Max ALT	Max Velocity	Max Vert. Velocity	Sanity Check	Max Pos. Deviation
<b>Airborne 2g</b>	Typical airborne environment; no 2-D position fixes supported.	50 km	250 m/sec	100 m/sec	Altitude	Large
<b>Airborne 4g</b>	Only recommended for an extreme dynamic environment; no 2-D position fixes supported	50 km	500 m/sec	100 m/sec	Altitude	Large

### 8.3.4 LED

The LED setting screen controls whether the LED is enabled or disabled. See **Figure 1** on **page 19** for the LED location on the SHOUT sp device.



*Figure 55: LED Option Screen*

- The LED is dark when the SHOUT app has the LED disabled or tracking mode is turned off.
- The LED blinks once every second if the SHOUT app is in tracking mode.
- The LED is on steadily if the SHOUT app is also in emergency mode.

## 8.3.5 SECURITY

The *Security Setting* submenu provides access to configure the *Encryption* and *Access Control List* functions.

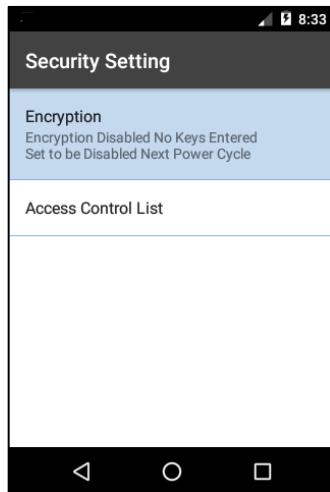


Figure 56: Security Setting Menu

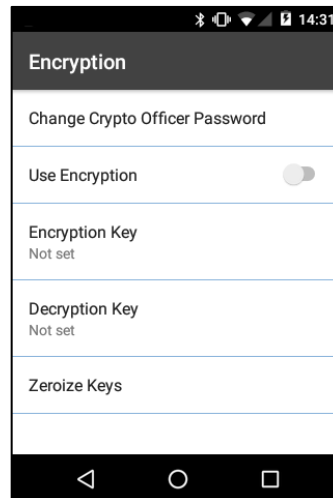


Figure 57: Encryption

### 8.3.5.1 ENCRYPTION

The SHOUT sp can send and receive data in AES 256-bit encrypted format. The *Encryption* settings menu provides a user interface to set up a *Crypto Officer* password, change the crypto keys, and enable/disable encryption.

First-time setup of the *Crypto Officer* password must be done before any encryption properties can be configured.

1. Press **Encryption** under the *Security Setting* menu.
2. Enter the New Password.

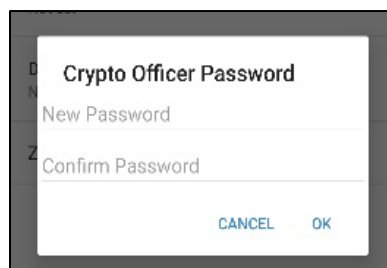


Figure 58: Crypto Officer Password

3. Confirm the password entry.

4. Press **OK** to allow entry of the *Encryption Key*.

NOTE: Subsequent entry into the *Security Setting* menu requires entry of the *Crypto Officer* password.

The *Encryption Key* must be set in order to use encryption. The *Decryption Key* is optional but is required to receive encrypted data. After an encryption key has been set, the *Use Encryption* option may be enabled.



Figure 59: Encryption Key

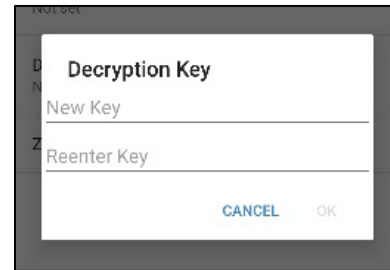


Figure 60: Decryption Key

The *Zeroize Keys* option, as shown above in **Figure 57**, removes both the encryption key and decryption key and disables the *Use Encryption* option.

### 8.3.5.2 ACCESS CONTROL LIST

The Access Control List (ACL) controls which functions to show in the menus. A checked item indicates the function is available, whereas an unchecked item indicates a hidden function. The list of options is organized by Settings, Tracking Profile Settings, Manage Data, and Operations. Access to this menu may be restricted by setting an ACL PIN through uploading a configuration file. See the **Configure From File** section **8.3.9** on **page 69** for more details about uploading a file.

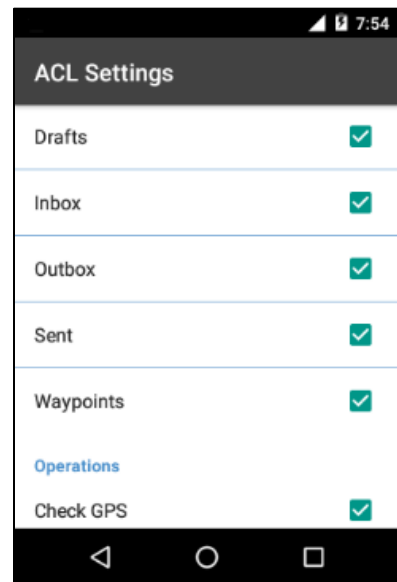


Figure 61: ACL Settings

### 8.3.6 TEXTING

The *Texting* settings submenu provides options to configure texting functions.

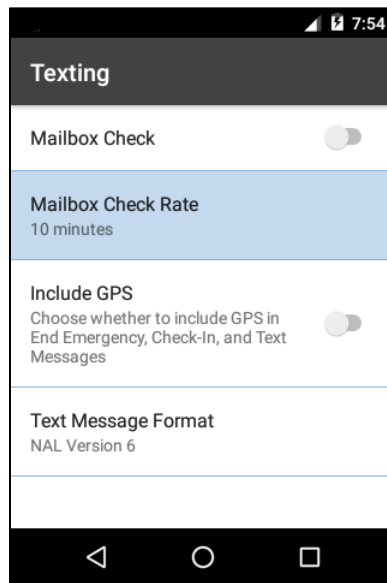


Figure 62: Texting

### 8.3.6.1 MAILBOX CHECK AND MAILBOX CHECK RATE OPTIONS

The *Mailbox Check* is used to enable or disable mailbox checking. The *Mailbox Check Rate* is used to schedule mailbox checks. Either enter a custom *Mailbox Check Rate* in minutes between (0–10080) or select from radio set options ranging from 1 minute to 7 days. The selected rate triggers the time for the app to initiate a check of the mailbox. This option only works when connected to the Iridium network.

### 8.3.6.2 INCLUDE GPS

The *Include GPS* option enables the device to attach the GPS location to Check-In, Canned messages, and Free-Text messages. Under default setting, these messages do not have GPS information included. Messages with GPS location attached can take longer to complete because the device has to acquire a GPS fix first. Depending on the validity of the stored ephemeris data, it could take an additional 29 seconds.

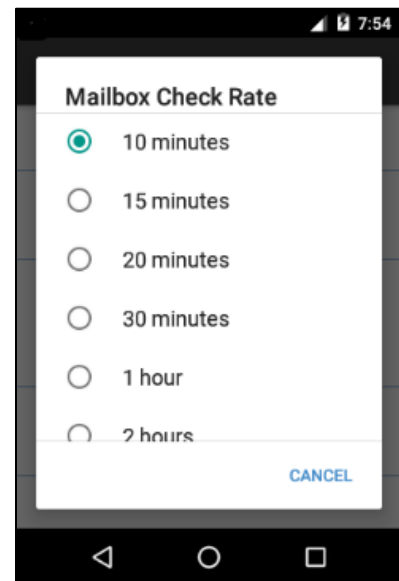


Figure 63: Mailbox Check Rate

### 8.3.6.3 TEXT MESSAGE FORMAT

This option allows the user to select either the *PECOS* or *NAL Version 6* text message formats used in outgoing text messages.

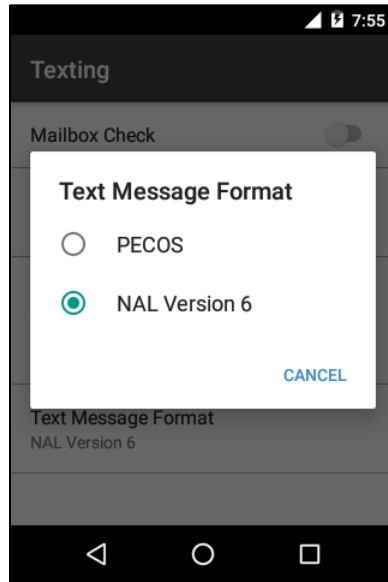


Figure 64: Text Message Format

### 8.3.7 TRACKING

The *Tracking* settings submenu provides options to configure tracking functions.

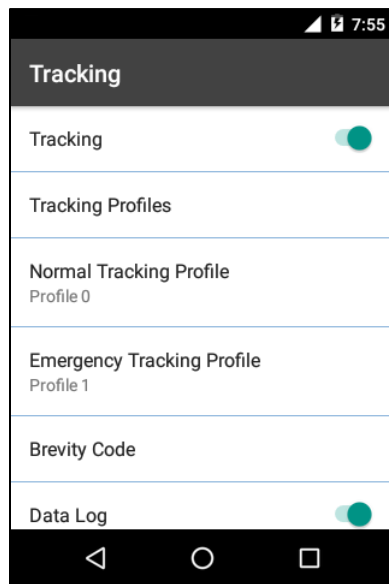


Figure 65: Tracking (Part 1)

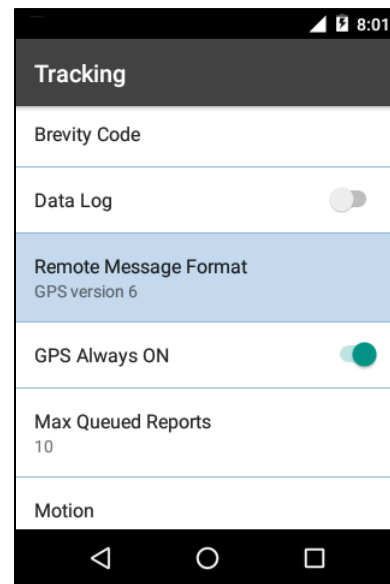


Figure 66: Tracking (Part 2)

#### 8.3.7.1 TRACKING

This option enables/disables tracking.

#### 8.3.7.2 TRACKING PROFILES

Tapping this option accesses a submenu for configuring the tracking profiles. There are 12 stored tracking profiles numbered from 0 to 11. These allow users to program their SHOUT sp

for many possible use cases; Foot Mobile, Foot Mobile Urban, Foot Mobile Mountainous Terrain, Slow Speed Vehicle Mounted (< 15 mph), Vehicle Mounted (15 – 30 mph), High Speed Vehicle Mounted (> 30 mph), Airborne (helicopter), Maritime, etc. Each of these scenarios will likely use different settings for tracking reports.

**Example 1:** A foot mobile military patrol may only need reports going once every ten minutes during a normal patrol. However, should they come in contact with enemy forces they may want those reports going once every minute.

**Example 2:** A National Park Service command center tracking forestry fire fighters may only want reports coming once an hour unless the fire fighters are within half a mile of the fire line, at which point they desire reports every two minutes.

In example 1 above, the Normal Tracking Profile selected for the SHOUT sp (it can be any of the 12 possible profiles) would have a report rate of 10 minutes, and the Emergency Tracking Profile (which can also be any of the 12 profiles) would have a report rate of one minute. The profiles are selected based on the user's or organization's needs. The Emergency Tracking Profile is activated by sliding the red Emergency Button Cover open and depressing the Emergency Button.

These profiles contain parameters that determine how the SHOUT sp operates when tracking is enabled. Tracking utilizes one of these stored profiles based on the current operating state. For example, under normal, non-emergency operation, the profile in use is set by the Normal Tracking Profile. Under emergency operation, the profile assigned to the Emergency Tracking Profile is used.

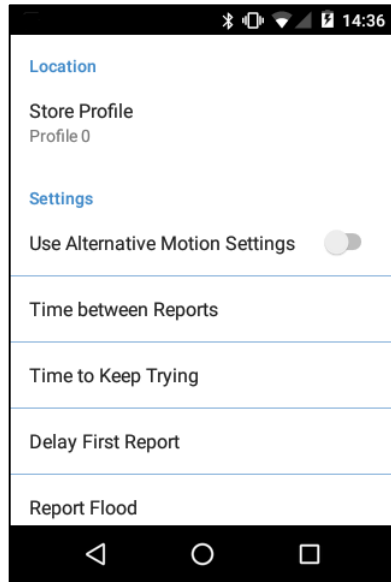


Figure 67: Tracking Profiles (Part 1)

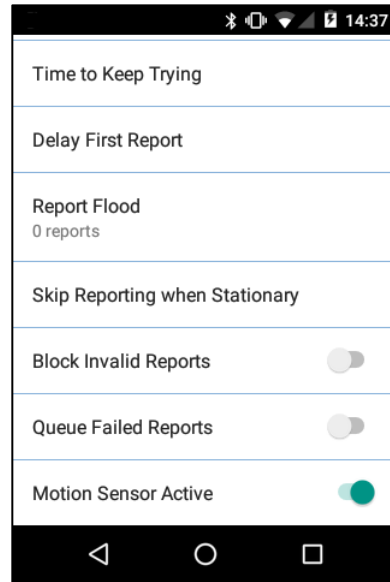


Figure 68: Tracking Profiles (Part 2)

In the following sections, settings can be configured on a per profile basis.

#### 8.3.7.2.1 USE MOTION SETTINGS

When motion of the SHOUT sp is being detected and the setting *Use Alternative Motion Settings* is enabled, the SHOUT app switches from the Standard settings to Motion settings of the values for *Time Between Reports*, *Time to Keep Trying*, and *Delayed First Report*.

#### 8.3.7.2.2 TIME BETWEEN REPORTS

This parameter sets the interval between tracking report cycles. The interval can range from 0 and 10080 minutes (168 hours or 7 days). There is a Standard and Motion value for this setting. The motion value applies when the *Use Alternate Motion Settings* option is enabled and the SHOUT sp device has detected motion. This parameter can also be modified from the *Tracking Menu* under the *Rpt Rate* icon.

Standard	10 minutes
Motion	5 minutes

Figure 69: Time between Reports

**IMPORTANT:** If organizations do not want their user’s modifying any of the settings associated with tracking they should lock these items from user access through the Access Control List.

### 8.3.7.2.3 TIME TO KEEP TRYING

This parameter sets the duration in which the SHOUT sp attempts to retry sending a tracking report. During a report cycle, the SHOUT sp attempts to acquire a valid GPS fix and Iridium signal. Once the GPS fix and signal strength requirements are met, the device sends a report. If the report fails to send, the SHOUT sp retries until the specified *Time to Keep Trying* window expires. There is a Standard and Motion value for this setting. The Motion value applies when the *Use Alternate Motion Settings* option is enabled and the SHOUT sp device has detected motion.

Standard	120 seconds
Motion	120 seconds

**Figure 70: Time to Keep Trying**

### 8.3.7.2.4 DELAY FIRST REPORT

When enabled, this setting prevents the transmission of the first tracking report. This applies when tracking is turned on or if there is a mode change. A mode change occurs when motion is detected or when emergency mode is enabled/disabled. There is a Standard and Motion value for this setting. The Motion value applies when the *Use Alternate Motion Settings* option is enabled and the SHOUT sp device has detected motion. An example of how this parameter might be useful is to avoid unwanted transmissions that may accumulate airtime costs. If tracking mode is restarting repeatedly because of frequent power cycling, reports will be transmitted each time. Enabling *Delay First Report* would delay that first report and reduce the airtime usage.

Standard	<input type="checkbox"/>
Motion	<input type="checkbox"/>

**Figure 71: Delay First Report**

### 8.3.7.2.5 REPORT FLOOD

This parameter, as seen in Error! Reference source not found., sets the number of tracking reports that are to be transmitted continuously when first entering tracking mode and when the tracking mode changes (for example, from Normal to Emergency). After the specified tracking reports have been transmitted, the pre-programmed reporting interval takes effect. In the Emergency tracking mode, the report flood ends prematurely when an emergency acknowledgement is received.

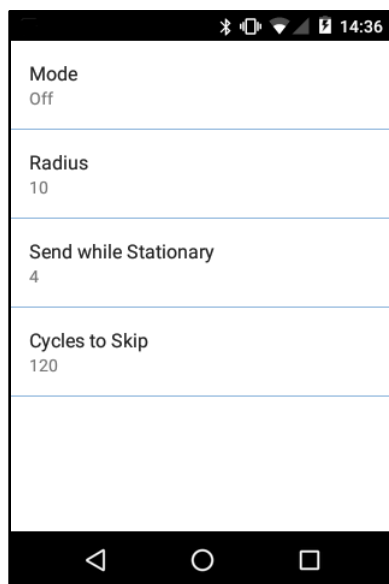


### 8.3.7.2.6 SKIP REPORTING WHEN STATIONARY

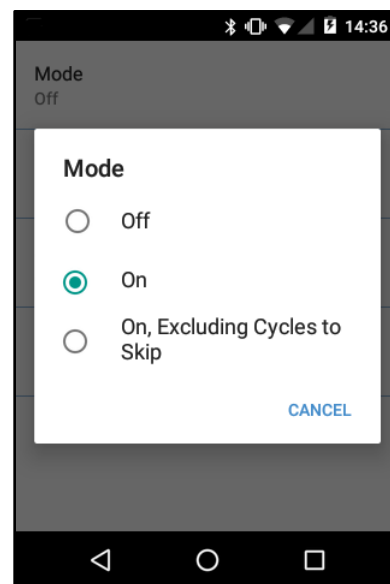
This function, as seen in **Figure 72** and **Figure 73**, limits the SHOUT sp from sending tracking reports when it has not moved out of a specified *Radius*. The three (3) *Modes* for this function include *Off*; *On*; and *On, Excluding Cycles to Skip*.

When the *Mode* is *On*, the device is bound to a sphere with a specified *Radius*. While the unit remains in the sphere, it sends a designated number of reports while stationary and then reports cease for a specified number of cycles. In the example below, once the unit is stationary it will send 4 reports (*Send while Stationary*) while inside the designated 10-meter *Radius*. The unit then stops reporting for 120 report cycles (*Cycles to Skip*). When the *Cycles to Skip* value is reached, the app reports for a specified number of *Send While Stationary* reporting cycles. The process is repeated until the device leaves the sphere. Upon leaving the bounding sphere, a new boundary is created at the current location of the unit and the app reports for the specified *Send While Stationary* cycles.

If the mode *On, Excluding Cycles to Skip* is selected, then the *Cycles to Skip* parameter is disregarded and the app reports for a specified number of *Send While Stationary* cycles each time a new sphere is established.



**Figure 72: Skip Reporting When Stationary Menu**



**Figure 73: Skip Reporting When Stationary Mode**

### 8.3.7.2.7 BLOCK INVALID REPORTS

The default setting is to send all tracking reports, even those with invalid GPS position. When this setting is enabled, only tracking reports with a valid GPS position fix are transmitted. This can be useful in filtering out possibly misleading GPS data points. The invalid GPS position could be a 2-D position with error exceeding 25 meters, a previously acquired position, or something highly inaccurate.

### 8.3.7.2.8 QUEUE FAILED REPORTS

By default, the SHOUT sp discards all tracking reports that acquired a good GPS position but failed to transmit. A tracking report that cannot be sent before the specified *Time to Keep Trying* value is considered a *failed report*. Queue Failed Reports allows the user to add these failed reports to the outbox to be re-sent at a later time.

### 8.3.7.2.9 MOTION SENSOR ACTIVE

When this option is *On* and the Tracking Profile Setting *Use Alternative Motion Settings* is *On*, the app switches to the Motion profile settings when motion of the SHOUT sp is detected.

### 8.3.7.2.10 NORMAL TRACKING PROFILE

This option sets the stored tracking profile to be used in Normal tracking mode.

### 8.3.7.2.11 EMERGENCY TRACKING PROFILE

This option sets the stored tracking profile to be used in Emergency tracking mode.

## 8.3.7.3 BREVITY CODE

The *Brevity* option selects which brevity code is included in PECOS formatted tracking reports (see **Appendix A: PMS Features**). The device ignores the brevity settings if PECOS format is not selected. With PECOS enabled, the user has the option to select any one of sixteen brevity codes (0000 through 1111) to be included in the PECOS tracking reports. These codes are represented by A, B, C and D and can be selected via checkboxes to select a specific brevity code. 'A' represents the least significant bit. For example, 'A' selected would yield the binary value 0001 while 'A' and 'C' selected.

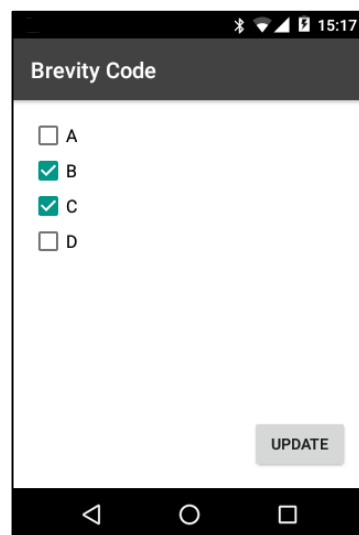


Figure 73: Brevity Code

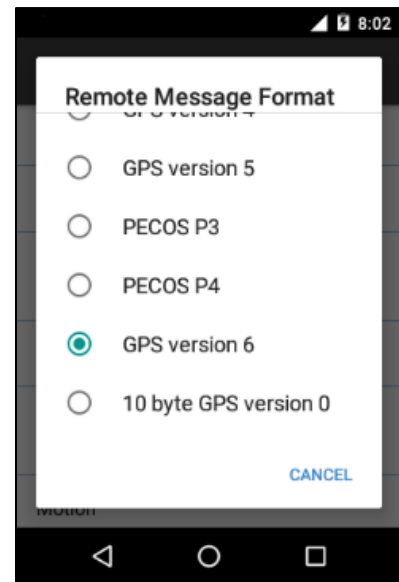
### 8.3.7.4 DATA LOG

The default setting is to log and save all position reports in memory. When the memory is full, the oldest reports are overwritten.

### 8.3.7.5 REMOTE MESSAGE FORMAT

This option sets the format of the messages that are sent from the SHOUT sp to a recipient. Currently available message formats are:

- **GPS Version 3:** Legacy format for compatibility.
- **GPS Version 4:** Legacy format for compatibility.
- **GPS Version 5:** Legacy format for compatibility.
- PECOS P3
- PECOS P4
- **GPS Version 6:** Used for NAL 30-byte message format. Includes position, velocity, figures of merit, motion and emergency flags, messaging short code and text fields.
- **10 Byte Version 0:** Useful for minimizing SBD data usage. Includes time of day, latitude, longitude, PDOP.



*Figure 74: Remote Message Format*

With UTC date omitted, the device relies on the NOC server to stamp the date as the report arrives. Latitude and longitude are recorded within ~1.1 meters in resolution. The 10-byte format is selected strictly for the purpose of Iridium airtime cost-saving. The PECOS Message Structure complies with the *Blue Force Tracking Data Format Specification*. [3]

### 8.3.7.6 GPS ALWAYS ON

This option forces the GPS receiver to remain ON in between reports allowing the SHOUT sp to have immediate location information (GPS hot start assuming the SHOUT sp always has full view of the sky) each time it is ready to transmit a tracking report. When power consumption is not critical, enabling this option is recommended for faster GPS acquisition and more accurate location information

## 8.3.8 MAX QUEUED REPORTS

This option sets the maximum number of reports that can be queued on the SHOUT sp for re-transmit. This setting applies only if either Queue Failed Reports.

### 8.3.8.1 MOTION

The SHOUT sp has a built-in sensor that can reliably detect motion. The *Motion* setting (**Figure 74**) provides users configurable motion characteristics.

When motion detection is enabled, the device monitors the motion sensor to detect when the device is in motion. Users can set the time to determine when motion has ceased (in figure 75 it is set to 2 minutes).

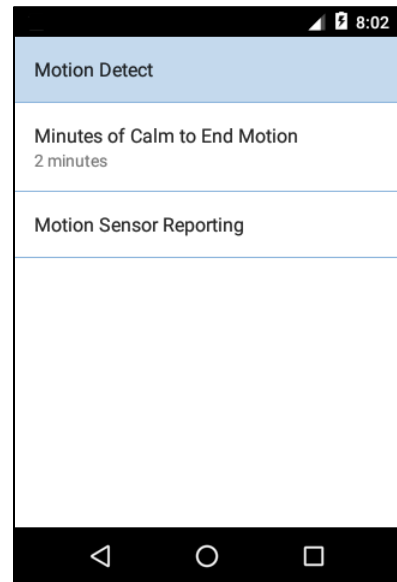


Figure 74: Motion

#### 8.3.8.1.1 MINUTES OF CALM TO END MOTION

This setting specifies the duration of calm needed in order for the device to return to the motionless state.

#### 8.3.8.1.2 MOTION SENSOR REPORTING

This setting determines whether to send a report when motion starts and/or when motion ends. If the *Report on Motion Start* option is enabled, a version 6 report with Short Code 20 is transmitted when motion is detected. If the *Report on Motion Stop* option is enabled, a version 6 report with Short Code 21 is transmitted when motion ends.

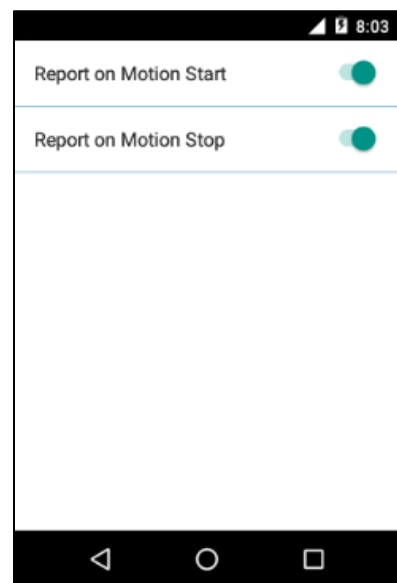


Figure 75: Motion Sensor Reporting

### 8.3.8.2 REMOTE UPDATE TIME CHECK

This enables a time check for incoming remote updates. When enabled, remote updates with a timestamp less than or equal to the last remote update time are not applied.

### 8.3.8.3 SUCCESSFUL SEND REQUIRED

This option restricts the SHOUT sp from changing to a lower priority tracking mode based on whether or not a tracking report has been transmitted. The tracking mode priority is Emergency first, followed by Normal. When set to *'Disabled. Tracking mode will switch immediately'*, a change to the tracking mode takes effect immediately (i.e., Emergency to Normal). When set to *'Must attempt one report before switching'*, the mode change is delayed until at least one tracking cycle is complete. When set to *'Must successfully send one report before switching'*, the mode change is blocked until a tracking report is transmitted successfully.

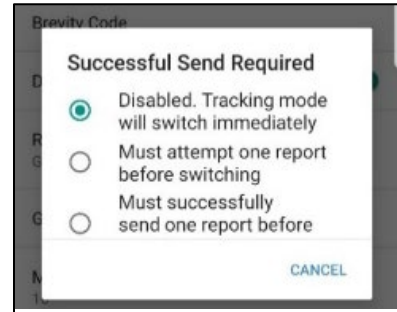


Figure 76: Successful Send Required

### 8.3.9 CONFIGURE FROM FILE

Settings available in the menus and some settings that are not can be loaded using a configuration file. The process involves a SHOUT sp connected to a Windows PC and following the steps laid out in this section.

#### ON THE SHOUT sp:

1. Connect the SHOUT sp to a computer using a USB-C cable.
2. Unlock the SHOUT sp to display the main screen with its application icons.
3. Swipe **Down** from the top of the SHOUT sp screen to display USB for charging notification (see **Figure 77**).

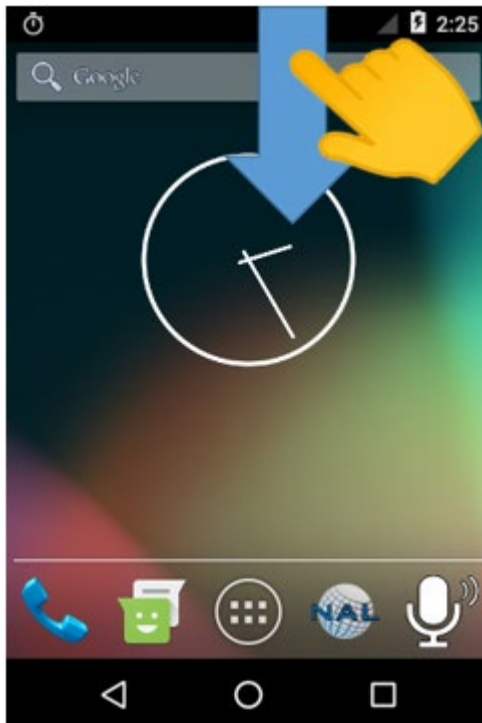


Figure 77: Swipe Down

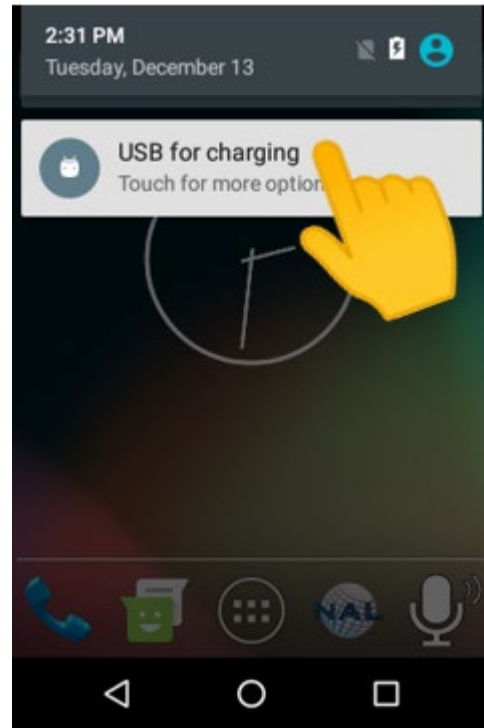


Figure 78: Tap USB for charging

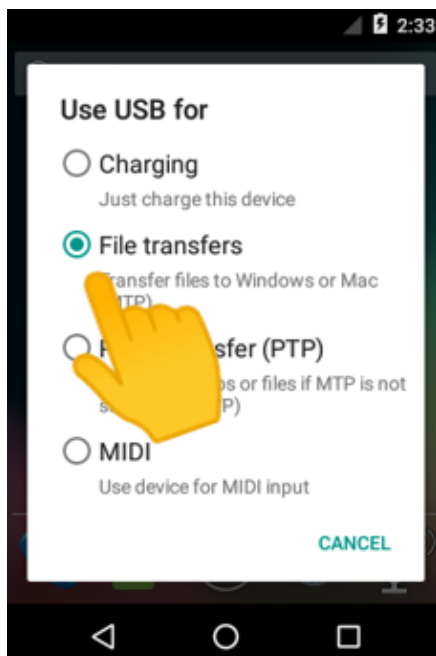
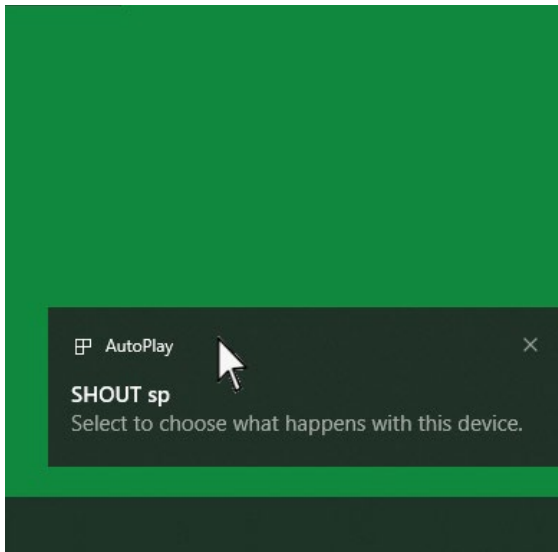


Figure 79: Select File transfers

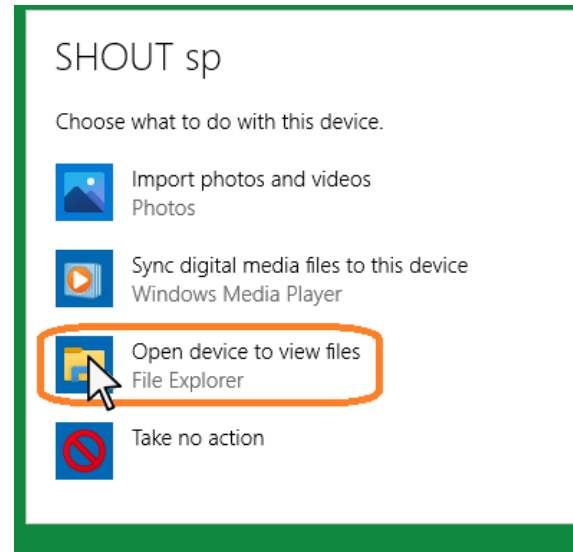
4. Tap **USB for charging** (see **Figure 78**), and select File transfers (see **Figure 79**).

**ON YOUR WINDOWS PC:**

5. Verify the *AutoPlay* popup window displays at the bottom of your PC (see **Figure 80**).



*Figure 80: Windows AutoPlay*



*Figure 81: AutoPlay Options*

6. Click the **AutoPlay** Popup notification to choose what to do with the plugged in device (see **Figure 80**).

- a. A secondary popup menu titled *SHOUT sp* displays (see **Figure 81**).

NOTE: If you need to redisplay the *AutoPlay* popup, reconnect the USB-C cable to the PC.

7. Select **Open Device to view files** to launch Windows File Explorer (see **Figure 81**).

NOTE: If you do not see the *AutoPlay* popup, right-click **Start**, scroll to and select **File Explorer** (see **Figure 82**).

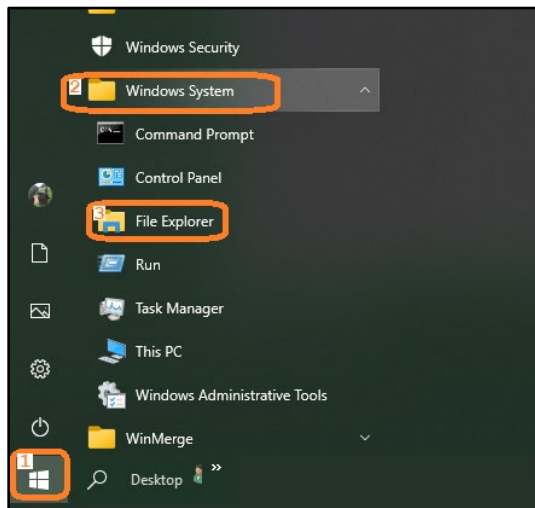


Figure 82: Launch File Explorer

8. From Windows File Explorer, navigate to the PC's folder containing the following file:  
*SHOUT\_sp\_config\_file.xml* (see **Figure 83**).

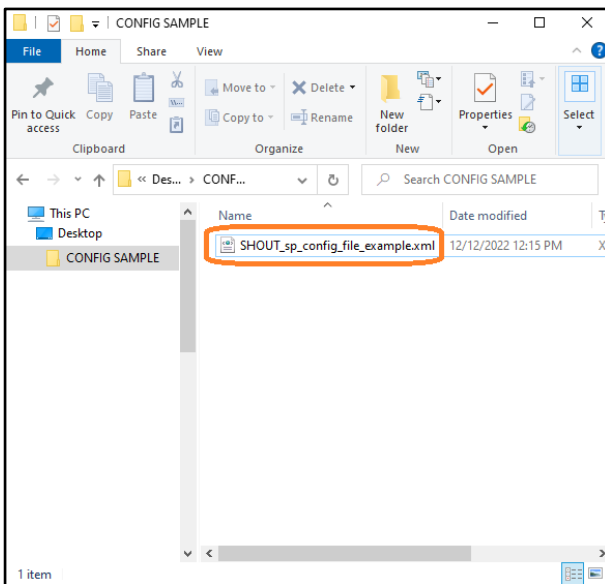


Figure 83: Find the XML file

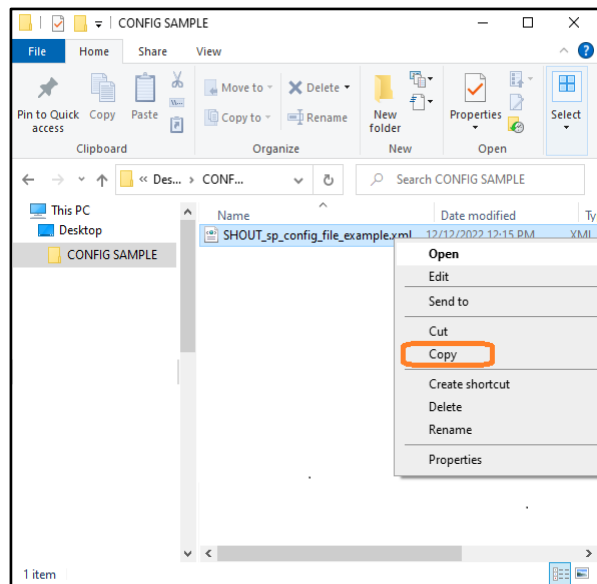


Figure 84: Copy the XML file

This should be the file that you want to use to configure your SHOUT sp device.

9. Right-click over **SHOUT\_sp\_config\_file.xml** (see **Figure 83**).

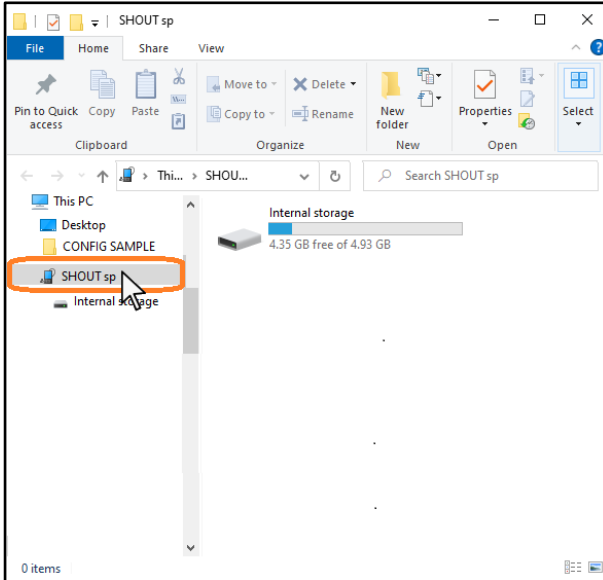
A popup menu displays (see **Figure 84**).

10. Select **Copy** (see **Figure 84**).

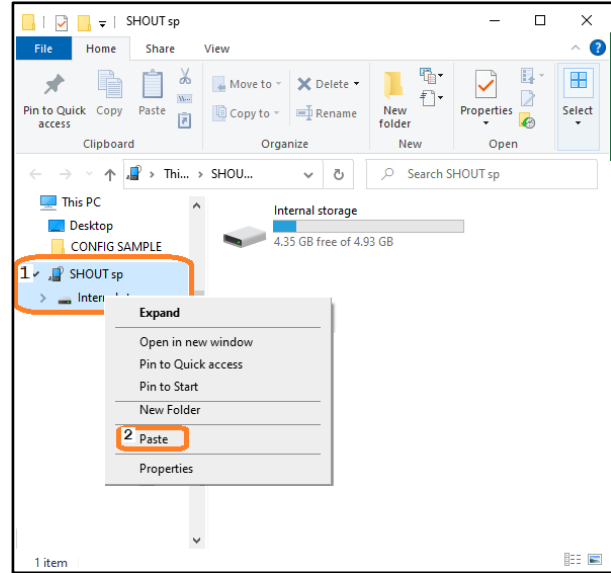


11. From within Windows Explorer, navigate to and double click the **SHOUT sp** icon (see **Figure 85**).

NOTE: It appears 'This PC' on the left side of File Explorer.



*Figure 85: SHOUT sp Icon*



*Figure 86: Copy the XML file*

12. Right-click over the **Internal Storage** icon on the right side of the File Explorer window (see **Figure 86**).

A popup menu displays (see (see **Figure 86**).

13. Select **Paste** (see **Figure 86**).

14. Double-click the **Internal Storage** icon to display the device contents, and verify the XML file has been pasted there.

**CONTINUE ON THE SHOUT sp:**

16. Tap the **NAL** icon to launch the SHOUT sp application (see **Figure 87**).

17. Tap the **Settings** icon (see **Figure 88**).

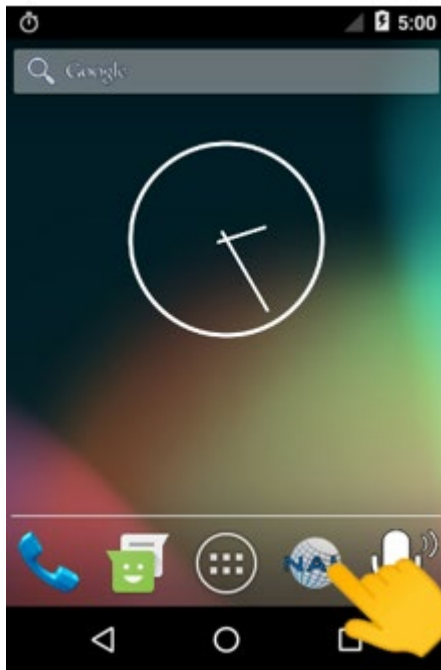


Figure 87: Launch the SP app

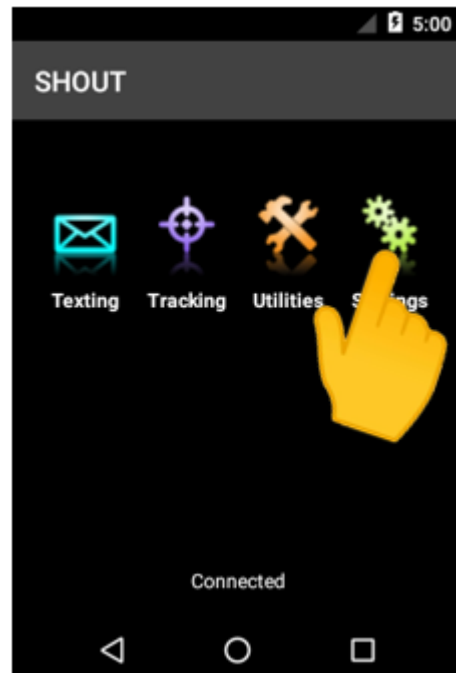


Figure 88: Tap Settings

16. Tap the **3 vertical dots** at the top right of the *Setting* screen (see **Figure 89**).

17. Tap **Configure from file** (see **Figure 90**).

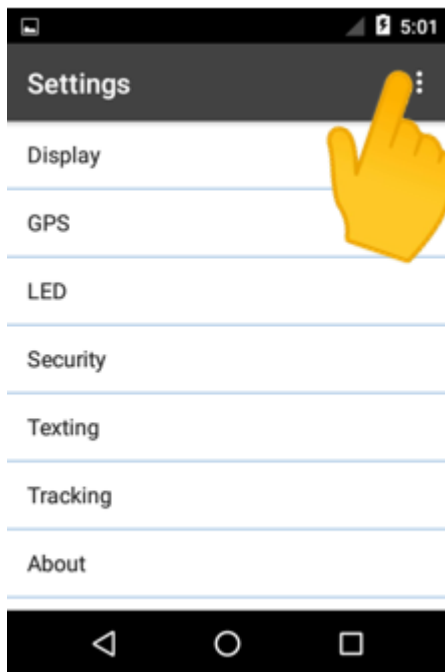


Figure 89: Tap 3 Dots at the top right of the *Setting* screen

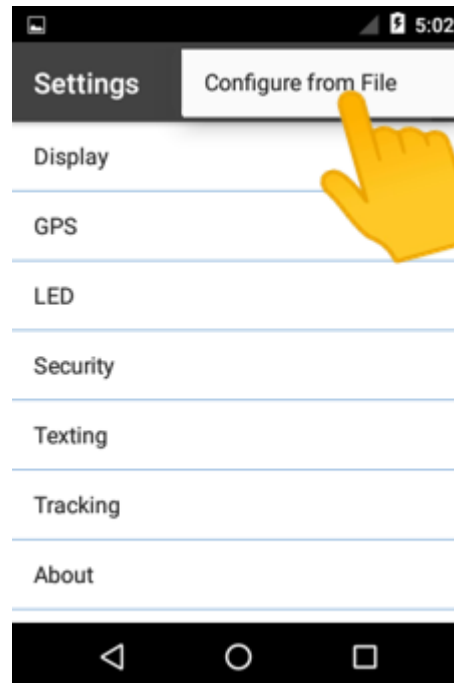


Figure 90: Tap *Configure from File*

13. Tap **Recent** (see **Figure 91**).

14. Tap the **3 vertical dots** at the top right of the Recent screen (see **Figure 92**).

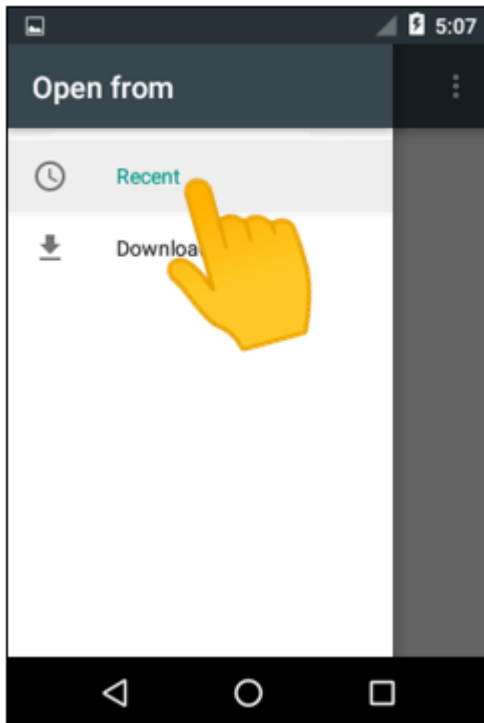


Figure 91: Tap Recent

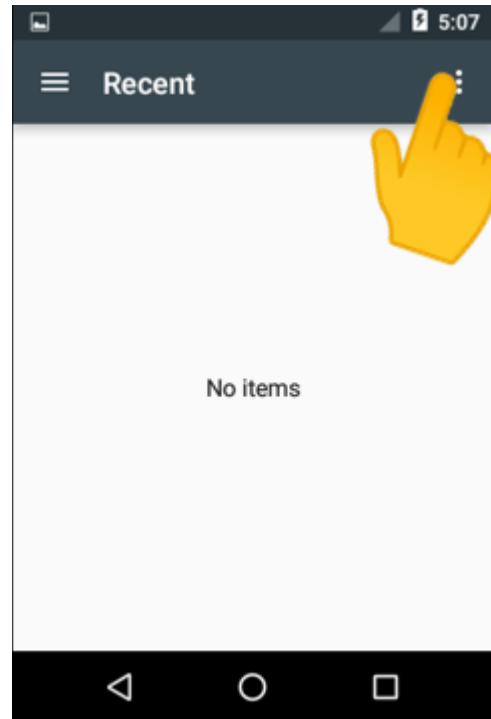


Figure 92: Tap Recent Options Menu

15. Tap **3 Lines** at the top left of the *Recent* screen (see **Figure 93**).

13. Tap **Show Internal Storage** (see **Figure 94**).

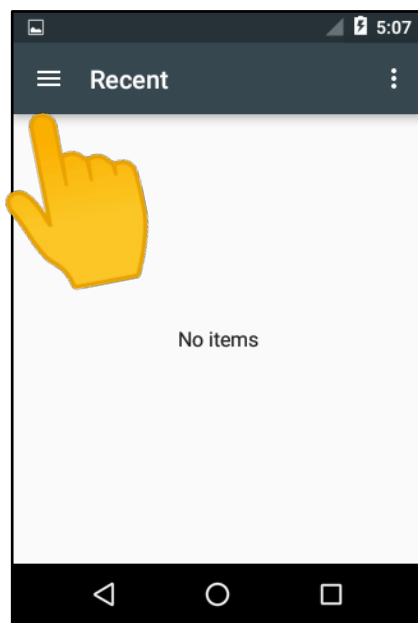


Figure 93: Tap 3 Line Icon

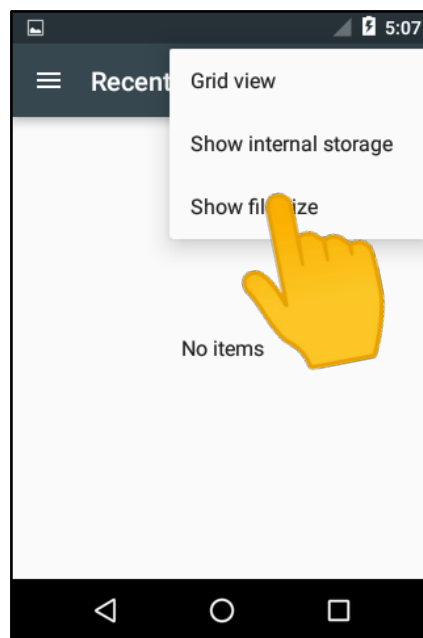
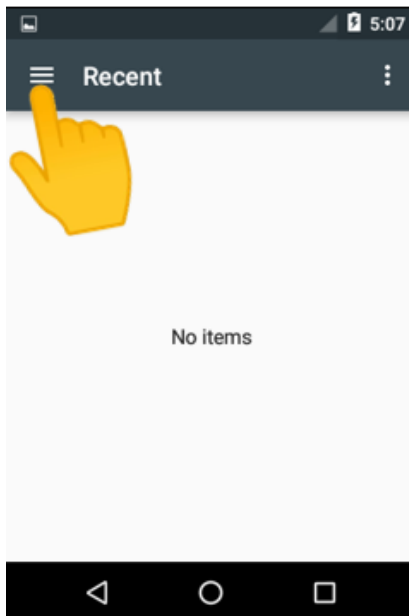
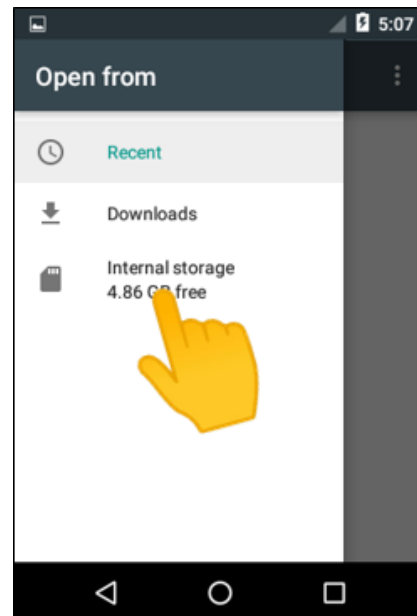


Figure 94: Tap Show Internal Storage

14. Tap **3 Line** icon (again) at the top left of the *Recent* screen (see **Figure 95**).
15. Tap **Internal Storage** (see **Figure 96**).



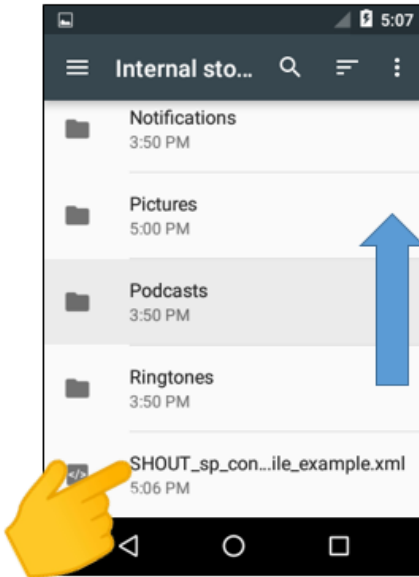
*Figure 95: Tap 3 line icon*



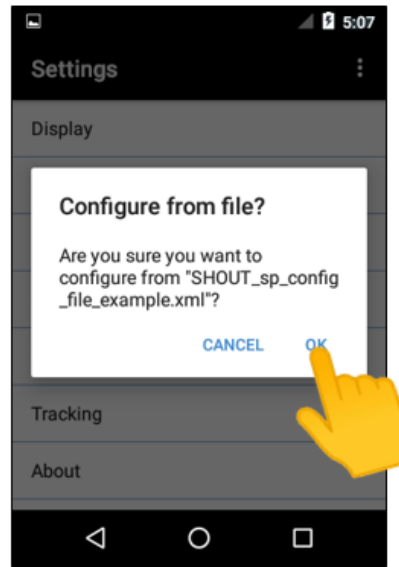
*Figure 96: Tap Show internal storage*

16. Scroll to and tap/select the XML file to be used for configuration (see **Figure 97**).  
The *Configure from file?* pop-up window displays (see **Figure 98**).
17. Tap **OK** (see **Figure 98**).

A Configuration success message appears (see Figure 99).

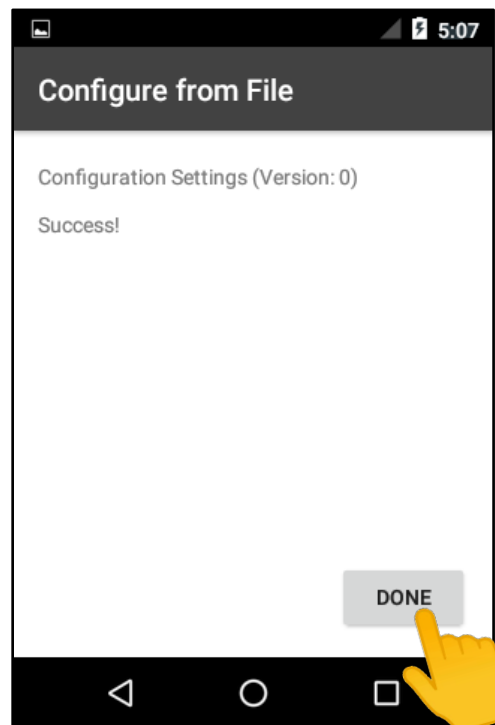


*Figure 97: Tap Recent to see Open menu*



*Figure 98: Configure Confirmation*

18. Tap **DONE** when you have successfully configured the SHOUT sp (see **Figure 99**).



*Figure 99: Tap DONE to close the process*

**Configuration From File FAILURES:**

- The most common reason for a failure is an improperly formatted XML file.

- If you see the message ***Invalid XML! Please check if the selected file is valid and try again.*** You will need to edit your XML file in an appropriate XML editor such as 'Notepad++' and 'Code Browser'.
- Be sure to select the XML language to see the XML tags match for proper XML formatting.
- You can edit the SHOUT sp Configuration file in an XML Editor to include as much, or as little of the Configurable Items as you like for each load. Be sure to keep the XML Tags.

## 9 NAL PUSH-TO-TALK [PTT] APP

The SHOUT sp comes with a preinstalled NAL PTT App. The app enables PTT communications between devices within preconfigured PTT talkgroups. The preconfigured talkgroups are maintained by the **Iridium Push-to-Talk Command Center**, which is available as a subscription service by Iridium Communications, Inc. Each SHOUT sp can be a member of up to 15 talkgroups arranged in numbered slots (1-15) and may have a 'Primary Talkgroup' assigned for special communication activities.

When the PTT app is running the user may scan talkgroups, listen to talkgroups, and communicate to selected talkgroups with the push of a button.

The PTT app has several device configurable options available in the PTT options menu. These include a Talk Timer, Location Sharing, Scan Period, Distance Formatting and whether to Enable the LED or not. Each are discussed in detail on the following pages.

At the top of the screen, the text *PTT* is displayed when the PTT mode has been activated. The *PTT* notification icon is visible from any screen currently being viewed by the user. The device operates in telephony mode for telephone calls and in PTT mode for push-to-talk functions. Only one mode functions at a time.

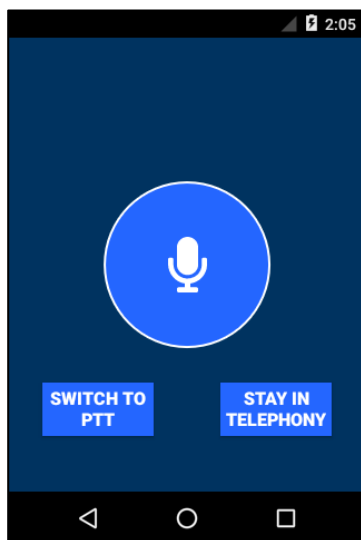


Figure 100: Mode Select

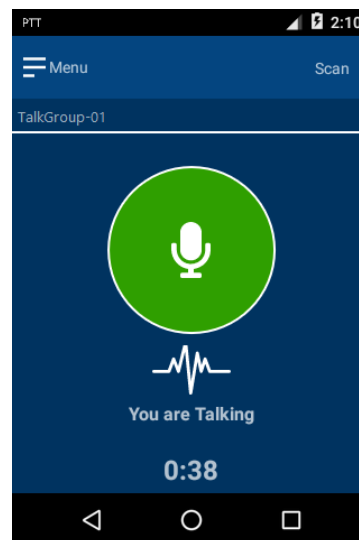
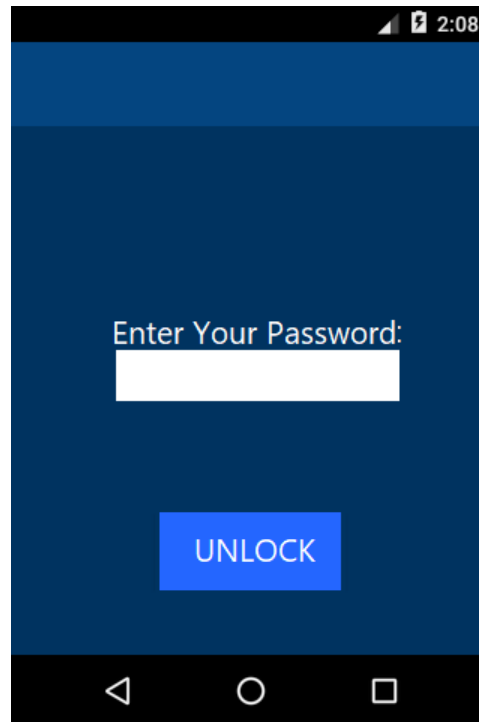


Figure 101: PTT Mode

## 9.1 LAUNCHING AND UNLOCKING THE PTT APP

Tap the *Microphone* icon found at the bottom of the SHOUT sp, or on the Android App screen, to launch the PTT app. The first time the app is run you are required to unlock the app by entering a password. The password is obtained by contacting NAL Research Corporation's customer support group. Provide the IMEI number of the device to the customer support representative and they will supply you with a password, which will unlock the PTT functions.



*Figure 102: PTT Password Entry*

**Note:** The IMEI is displayed in Android **Settings>About Phone >Status>IMEI Information**.

## 9.2 PTT APP SCREENS

### 9.2.1 MODE SELECTION

When the PTT app launches options appear to *Switch to PTT* or *Stay in Telephony* mode. Press **Switch to PTT** to connect to the Iridium network in PTT mode. The PTT icon highlighted in **Figure 103** is displayed in the top-left corner of the device when the device is in PTT mode. Telephony functions will not function while the device is in PTT mode.



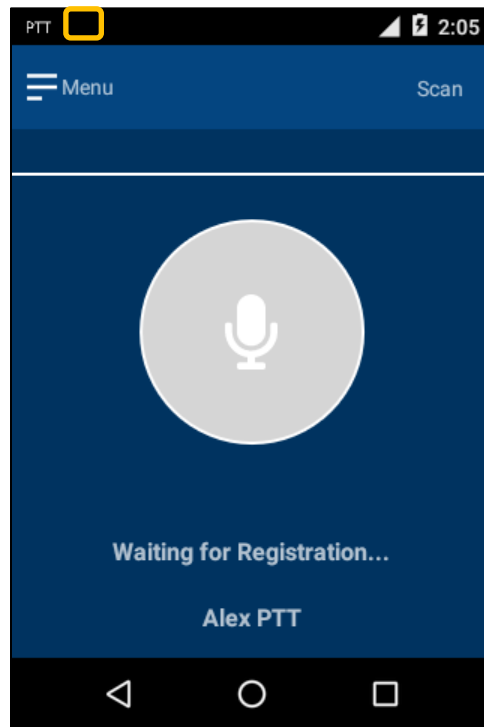
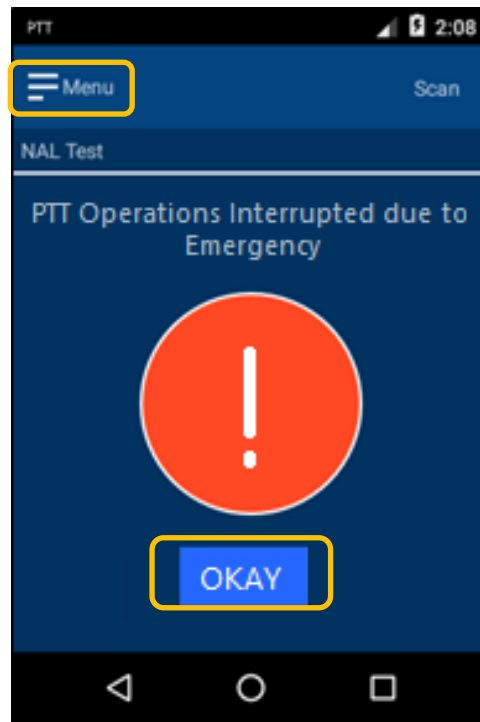


Figure 103: PTT Registration

## 9.2.2 911 STATUS

If the *Emergency* button is pressed while in PTT mode, a notification appears that PTT mode has been interrupted and Emergency Tracking Mode has started.

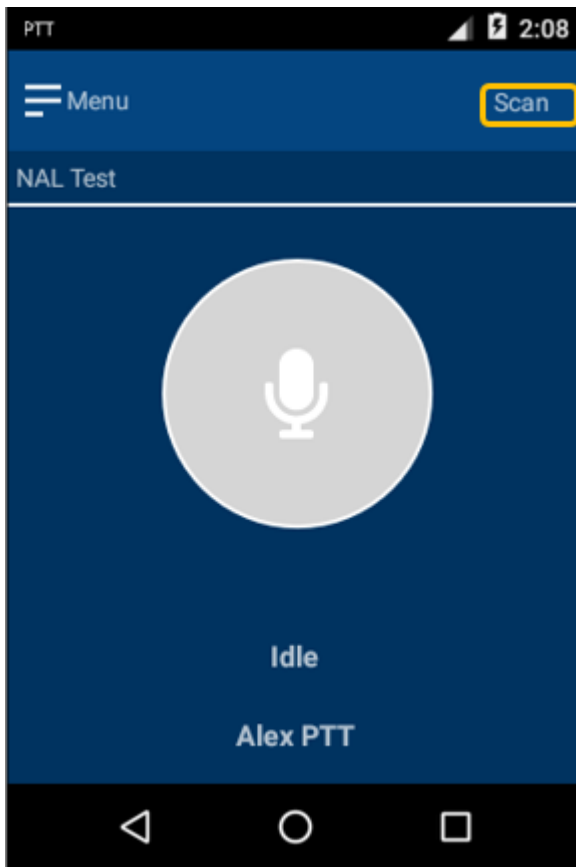
1. Press **OKAY** to confirm understanding of the switch to *Emergency Tracking Mode* (see **Figure 104**).
2. After the emergency mode has been canceled, press the **Menu** button.
3. Press the **Switch to PTT** option when ready to return to PTT Mode.)



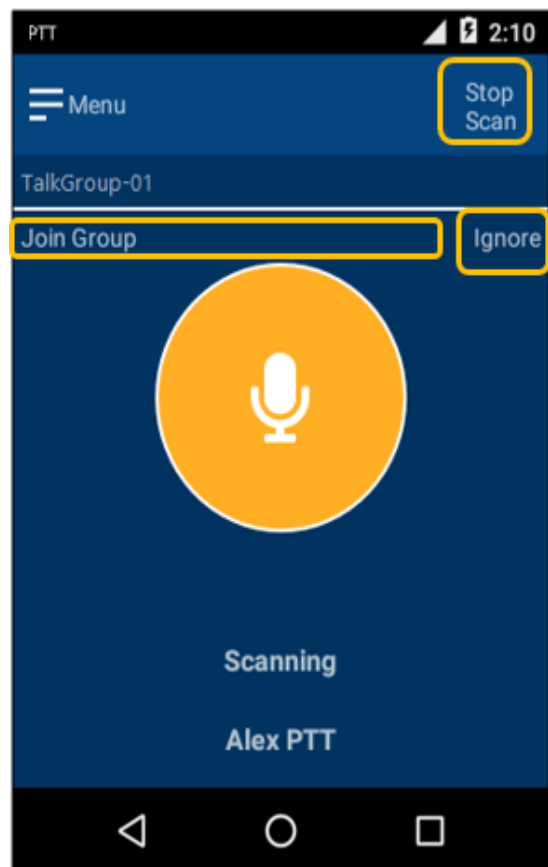
*Figure 104: Emergency Mode*

### 9.2.3 IDLE AND SCANNING STATE

Each time the app launches and the PTT mode is selected, the device goes through a registration process while connecting to the Iridium network. Once the device has been registered, the name of first talkgroup appears under the menu button, as highlighted in **Figure 105** below. If there is no activity in the current talkgroup by any of its members, the device status is *Idle* and the microphone circle icon displays with a gray background. The microphone circle icon changes to an exclamation point circle icon when the device's 'Priority Talkgroup' is being monitored.



*Figure 105: PTT Idle*



*Figure 106: PTT Scanning*

- Press the **Scan** button to scan all of your active talkgroups for a configurable period (see **Figure 105**). The active talkgroup name appears under the menu button.
- Press **Join Group** to stop scanning and join the current talkgroup (see **Figure 106**).
- Press **Ignore** to ignore the current talkgroup and continue to scan the remaining talkgroups (see **Figure 106**).
- Press **Stop Scan** to stop scanning all active talkgroups (see **Figure 106**).

## 9.2.4 OPEN AND LISTENING STATE

When a talkgroup has members who are actively listening or scanning, but no one is talking, then the device is considered to be in an *Open* state and the text 'Open' is displayed under the blue microphone circle icon. As members of a talkgroup start to speak, the device switches to a *Listening* state. The text 'Listening' appears under a blue microphone circle icon. If listening to someone talking from your 'Priority Talkgroup', a green background is displayed behind a blue exclamation point circle icon.

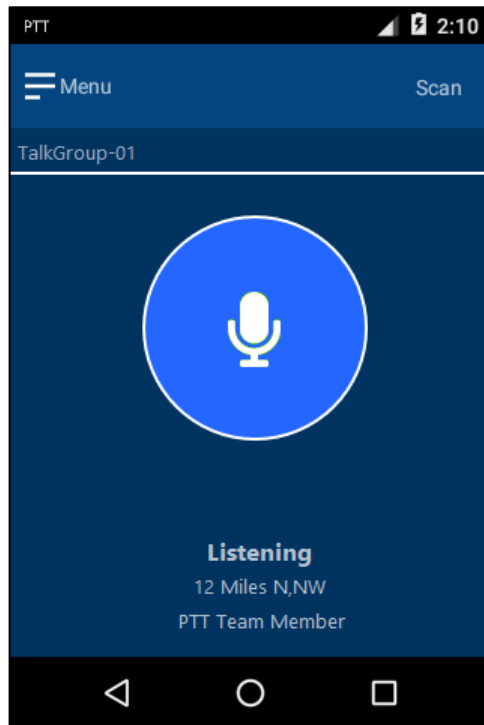


Figure 107: PTT Listening

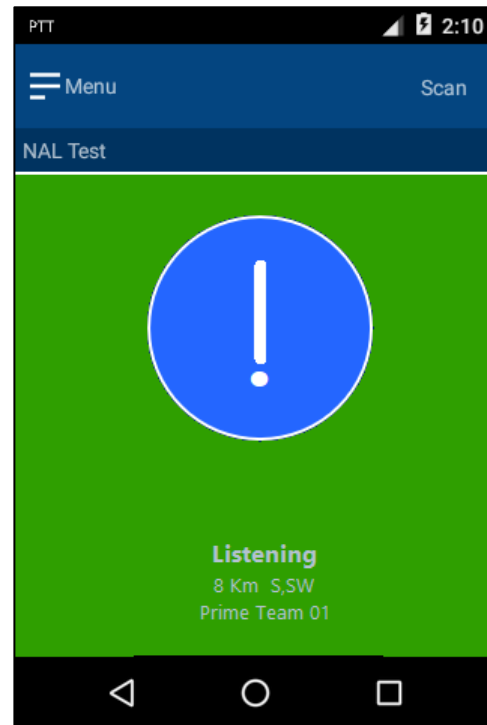
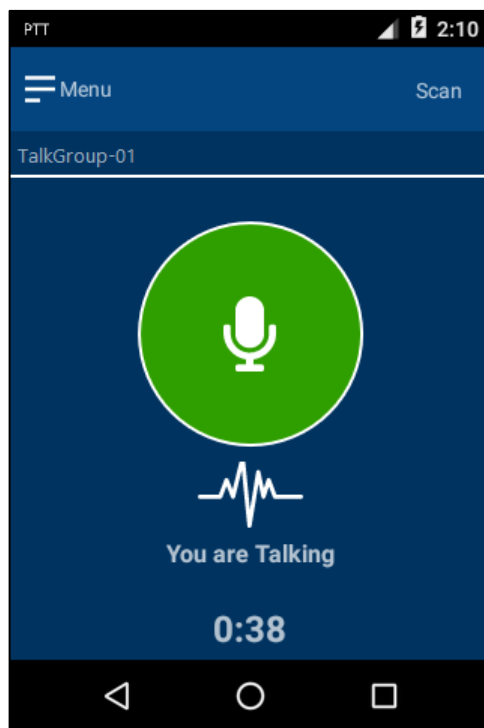


Figure 108: PTT Priority Talkgroup Listening

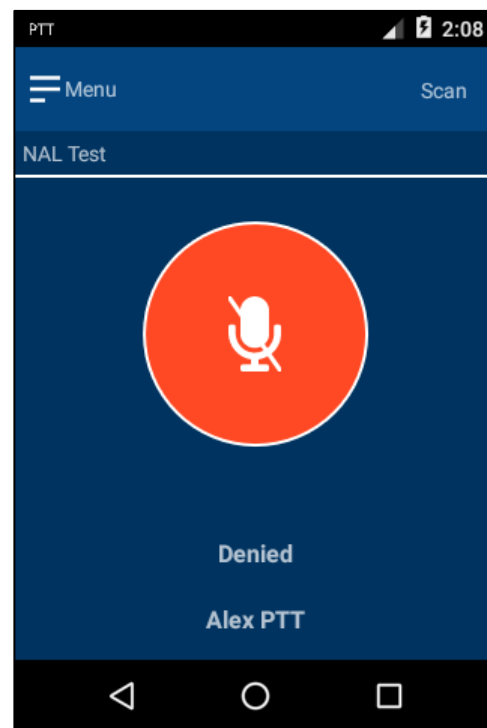
## 9.2.5 TALKING AND DENIED STATE

When the floor is open and you wish to speak to the current talkgroup, press and hold the PTT button on the right side of the SHOUT sp. If the network grants you time to talk, the text 'You are Talking' is displayed under a green microphone circular icon. Your configurable talk time counts down the seconds left in your allotted time. Release the PTT button to stop talking at any time.

If the network denies you access to talk, the text 'Denied' is displayed under a red microphone circular icon. Press and hold the PTT button again to try to request the floor.



*Figure 109: PTT Talking*



*Figure 110: PTT Denied Talking*

## 9.3 PTT OPTIONS AND SETTINGS MENU

PTT options and settings are available to tailor the PTT experience to the user's specifications. Access options and settings by pressing the menu button at the top-left corner of the PTT app.

### 9.3.1 SWITCH TO PHONE

Press **Switch to Telephony** to switch to telephony mode when the device is in PTT mode. Press **Switch to PTT** to switch to PTT mode when the device is in telephony mode. Each action presents the user with a *Switch Mode* confirmation screen as seen in **Figure 112**.

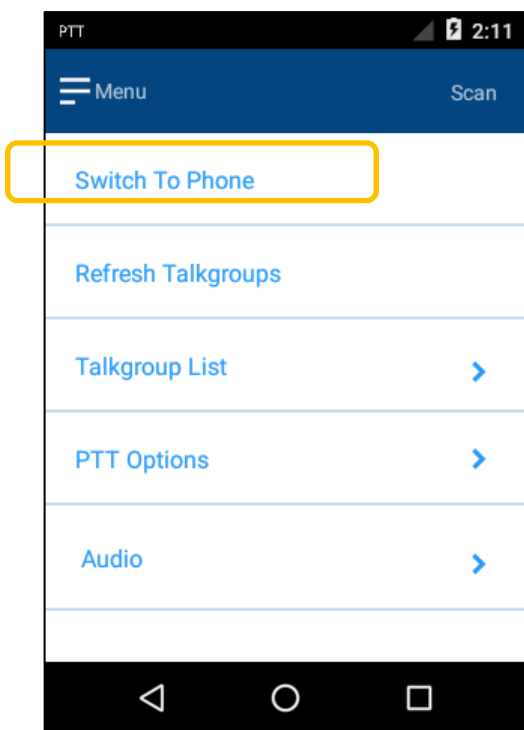


Figure 111: Switch Mode

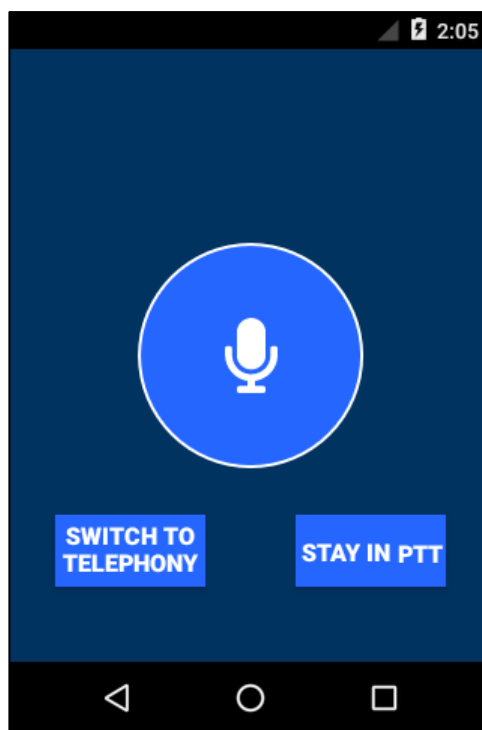


Figure 112: Switch Confirmation

### 9.3.2 PTT REFRESH TALKGROUP

The latest preconfigured talkgroups are loaded onto the SHOUT sp each time the PTT app registers the device with the Iridium network. If the talkgroup configuration changes while the PTT app is currently running, the app provides an option to refresh the talkgroups. Press **Refresh Talkgroups** to update the SHOUT sp with the current configured talkgroups. The *Refresh Talkgroups* confirmation screen opens. See **Figure 114** below. The refresh process may take up to 10 seconds to complete.

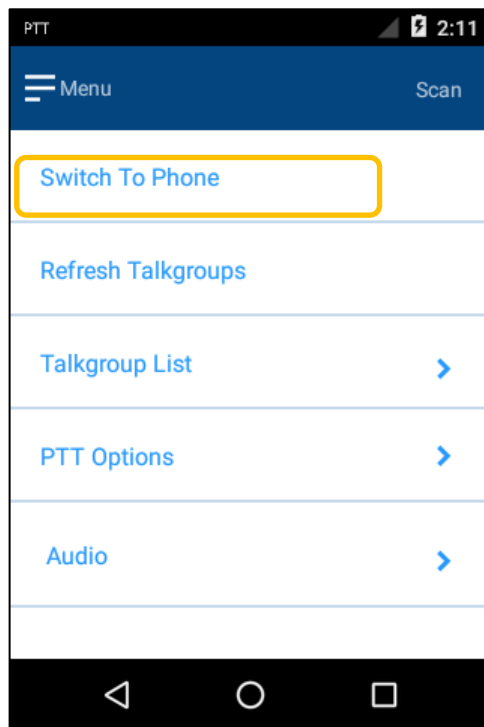


Figure 113: PTT Menu

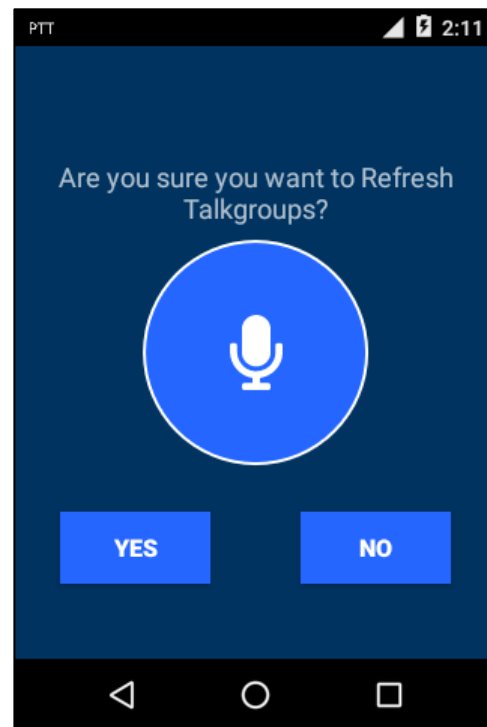


Figure 114: PTT Refresh Talkgroup

### 9.3.3 TALKGROUP SELECTION

Press **Talkgroup List** to view a list of the configured talkgroups that you may interact with. The microphone icon indicates the current talkgroup you have joined. The exclamation point icon points to your 'Priority Talkgroup'.

Scroll to the desired talkgroup you would like to join. Press and hold (long press) the talkgroup in the list to join it as your current talkgroup.

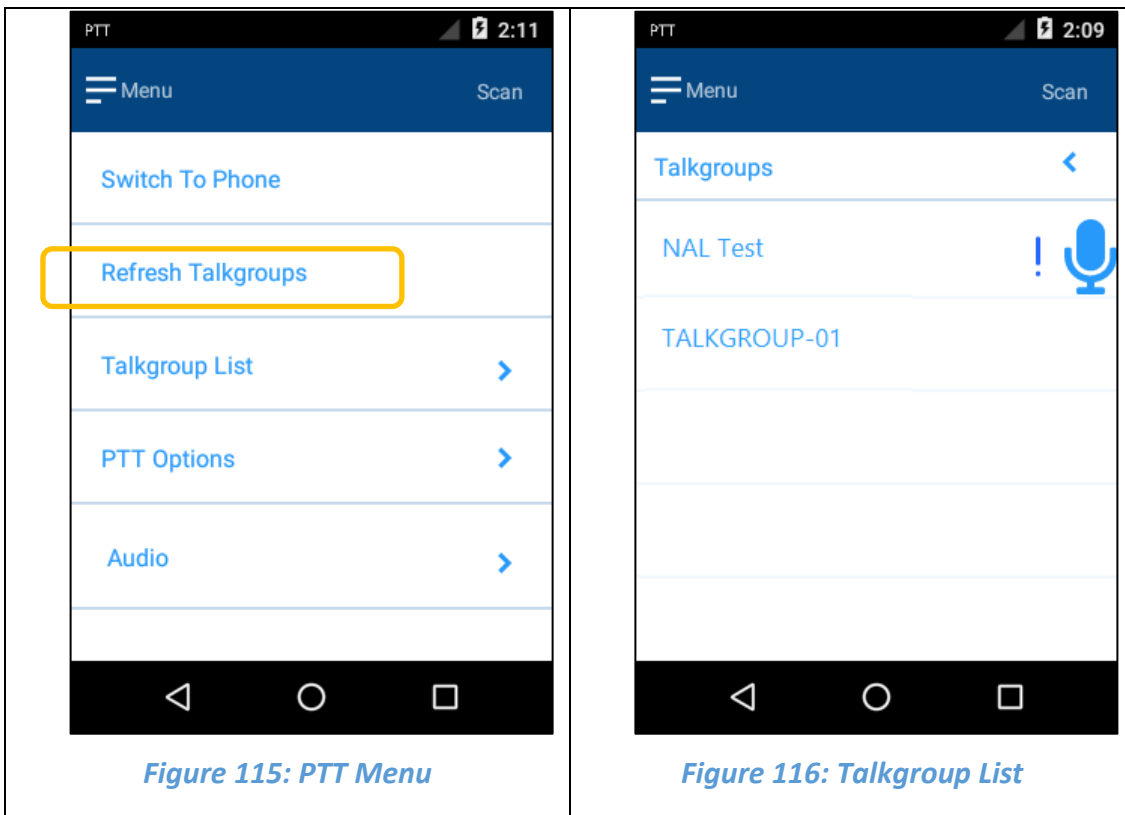


Figure 115: PTT Menu

Figure 116: Talkgroup List

### 9.3.4 PTT OPTIONS

Press **PTT Options** to view a list of options to customize your PTT user experience.

- Toggle the **Talk Timer** on to display a countdown of the allotted talk time at the bottom of the screen as seen in **Figure 109**. The countdown timer runs from 40 seconds to zero. Toggle the *Talk Timer* off to hide the countdown timer.
- Toggle the **Location Sharing** on if you would like to display your relative location to the SHOUT sp devices listening to you while you are talking. Toggle the **Location Sharing** off to hide your relative location from SHOUT sp devices that are listening to you while you are talking.
- Select the **Scan Period** for monitoring active talkgroups while scanning them. The options are 10, 15, or 20 seconds.
- Select the **Distance Format** to display when sharing your location represented in miles or kilometers.
- Toggle **Enable LED** on to display the LED on the SHOUT sp. Toggle **Enable LED** off to keep the LED off.



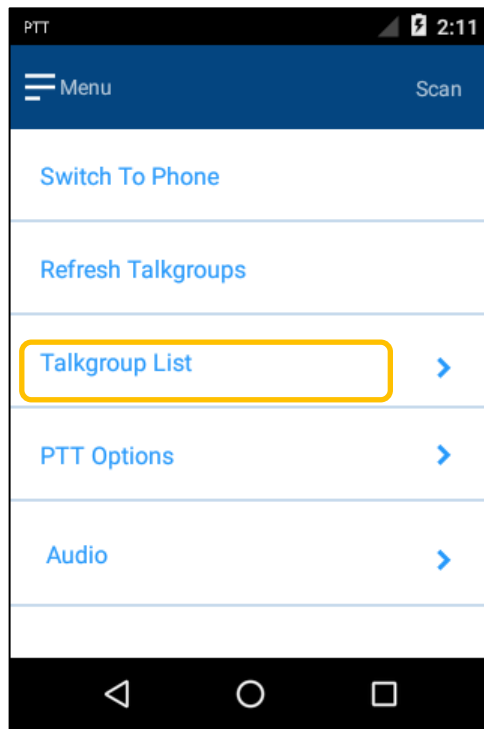


Figure 117: PTT Menu

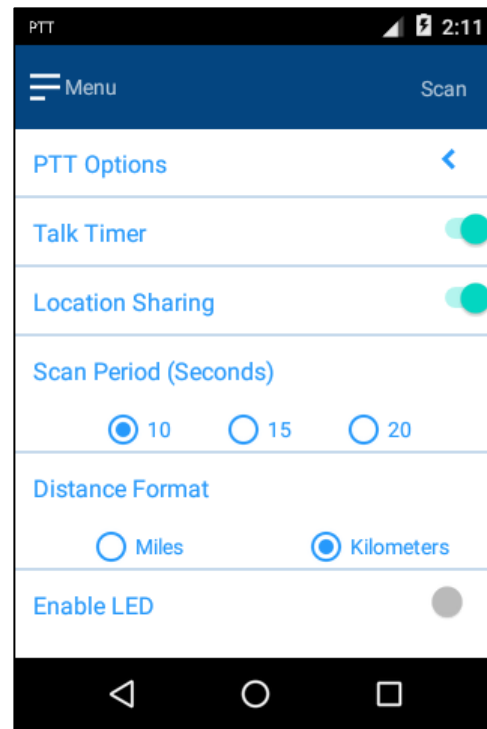


Figure 118: PTT Scanning

LED	Indication while in PTT Mode
OFF	PTT service not provisioned and/or network is unavailable
Blinking Green	PTT service and network are available
Blinking Blue	PTT service provisioned but network is unavailable
Alt. Blue/Green	PTT in use (Talking, Listening, Open)
Solid Green	Device is in emergency mode (Emergency button was pushed)

### 9.3.5 AUDIO OPTIONS

Press the **Audio** option to view a list of the available audio settings. Toggle the speakerphone on to rout the audio to the speakerphone on the back of the SHOUT sp, or toggle it off to have the audio be heard through the earpiece on the front of the device. The audio output may be increased up to seven by pressing the right arrow, or decreased to zero by pressing the left arrow.

This volume adjustment is in addition to the regular volume levels made by the pressing the SHOUT sp volume up and down buttons.

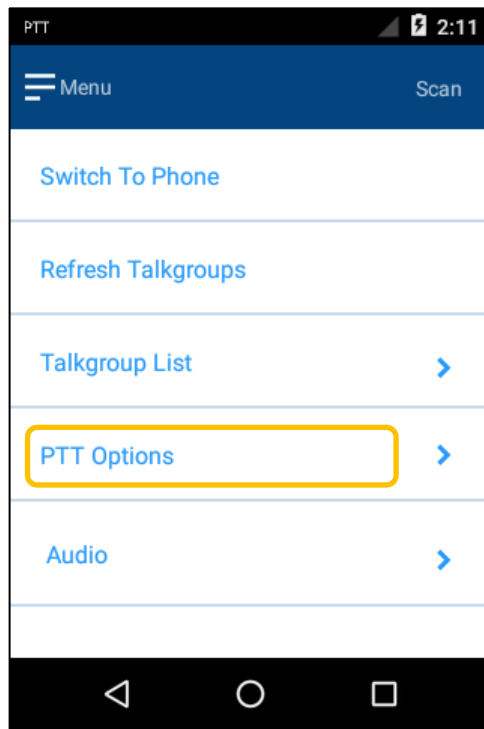


Figure 119: PTT Menu

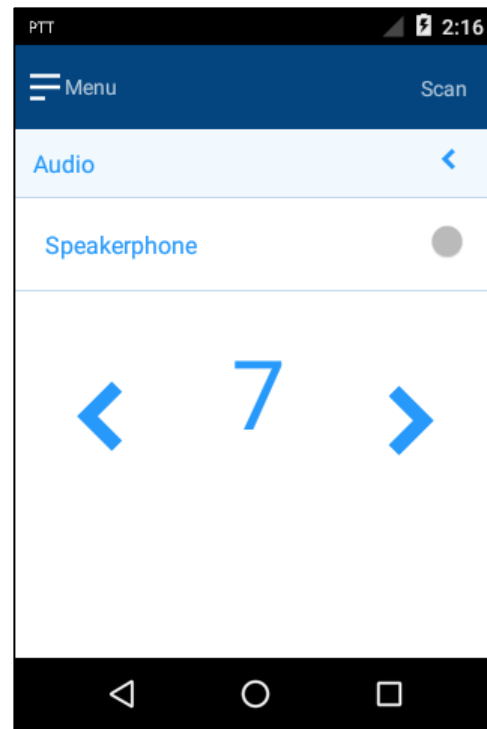


Figure 120: Audio Options

## Appendix A: PMS FEATURES

### A-1. TRACKING



The SHOUT sp is capable of sending position reports in PECOS Message Structure (PMS). PMS complies with the Blue Force Tracking Data Format Specification as defined in the document PECOS 200907-001 Version 1.7 [3].

### A-2. BREVITY



With PMS enabled, you can select any one of sixteen brevity codes (0000 through 1111) to be included in the PMS tracking reports. These codes are represented by A(z), B, C(z) and D, and can be selected via the touchscreen. Each code displays as a green checkmark next to the brevity code when selected.

### A-3. CONTACTS



With PMS enabled, the contact(s) must have two (2) fields—Name and IMEI number. The *Contacts* function allows users to enter and save a contact(s) via the keyboard.

### A-4. COMPOSE



With PMS enabled, users must choose contacts from the contact list and not enter e-mail addresses directly. The contact(s) must have two fields—Name and IMEI number.

## Appendix B: UPGRADING THE FIRMWARE

The SHOUT sp firmware can be upgraded using a computer connected to the USB port of the device. Contact NAL Research Tech Support by dialing 703.392.1136 or emailing [support@nalresearch.com](mailto:support@nalresearch.com).

# Appendix C: DESIGN SPECIFICATIONS

## C-1. SHOUT sp

### Mechanical Specifications

Dimensions:	4.9" x 2.7" x 0.9" (127 x 69 x 23 mm) (without antenna)
Weight:	~12 oz. (340 g)
Enclosure:	Hard anodized aluminum housing / EMI shielding / ABS plastic radome
Connector:	USB-C, SIM reader, 3.5 mm headset jack
Antennas:	External Iridium, embedded GPS, and embedded W-Fi / Bluetooth
Buttons:	Power, Volume Up, Volume Down, PTT, Covered Emergency
Emergency:	Guarded button
LED:	One status LED
Screen:	3.0" TFT 400 x 240-pixel capacitive LCD
Audio:	Microphone, earpiece speaker, hands free loudspeaker

### Electrical Specifications

Main Input Voltage:	2.75V DC to 5.5V DC
Peak Current:	1.5A @ 5.0V DC
Battery Type:	Lithium Ion
Battery Capacity:	2.15 A-Hr.
Charging Voltage:	USB 1.0, USB 2.0 or 5 VDC
Rechargeable Cycles:	> 500 times

### Iridium Transceiver

Operating Frequency:	1616.0 to 1626.5 MHz
Duplexing Method:	TDD
Multiplexing Method:	TDMA/FDMA
Link Margin Downlink:	12 dB average (free space)
Link Margin Uplink:	12 dB average (free space)
Average Transmission Power:	1.0W



### Micro SIM Card Specifications

SIM Card Height: .....15 mm  
SIM Card Width: .....12 mm

## C-2. SHOUT SP MOUNT DESIGN SPECIFICATIONS

### C-2.1. HANDHELD SPEAKER-MICROPHONE

#### Mechanical Specifications

PTT switch: .....1,000,000 cycles minimum  
Clothing Clip Ass.: .....360 degree rotatable w/ positive detent  
stops every 45 degrees  
Cable Ass.: .....Min flex life of 10,000 stretches and 25,000  
rock and twist cycles\*  
Cable pull force: .....50lbs max

\* 270 degree rock and 90 degree twist when cable is flexed @ 3:1 ext. ratio

#### Speaker Audio

Max output level: .....120dB SPL  
Nominal output level: .....91dB +/- 4dB SPL1.5A @ 5.0V DC  
Distortion @ nominal output:.....15%  
Battery Capacity: .....2.15 A-Hr.

#### Microphone Audio @1KHz

Type: .....Omni Directional, Knowles™ Surface MEMS  
Microphones  
Distortion: .....2%  
Sensitivity:.....-42dB ± 4dB  
Frequency Response: .....Frequency Response 50-16KHz

#### General/Other

Earphone jack: .....3.5mm standard  
Cord Length: .....2500mm (fully extended)  
IP rating: .....IP67





## C-2.4. CAR CHARGER POWER CABLE (3FT)

### General

I/O Cable Type:	USB-C cable
Cable Subcategory:	USB
Shielding Material:	Aluminum mylar foil with braid
Jacket Material:	Thermoplastic elastomer (TPE)
Left Connector:	Type24 pin USB-C
Left Connector Gender:	Male
Left Connector Design:	Straight/locking
Right Connector:	Type24 pin USB-C
Right Connector Gender:	Male
Right Connector:	Qty1
Right Connector Design:	Straight
American Wire Gauge (AWG):	30/32
Plated Connector:	Nickel
Compliant Standards:	USB 3.2 Gen 2/ DisplayPort 1.4/Thunderbolt 3
Cable Key Features:	8K support
Cable Features10:	Gbps data rate, DisplayPort Alternate Mode support, EMI protection, Outer diameter 4.8 mm, Power Delivery (PD) technology
Connector (Second End)	24 pin USB-C - male – straight
Color	Black, Gray
Color Category	Black, Gray
Compliant Standards	RoHS, WEEE
Length	3.3 ft

## C-2.5. DOCKING STATION POWER CABLE (6FT)

### Electrical

Cable Spec.: .....NO—UL 32AWG  
 (7/0.08TC)\*1P+32AWG(7/0.08TC)\*1C+2  
 4AWG26/0.1TC+25OD)\*1C+3E(19/0.05T  
 C+25OD)+AB(16/9/0.06TC 95%TC)

OD: .....3.0mm ~ Black

Rated Temperature: .....80°C ; Voltage: 30 V

Max Conductor Resistance at 20°C: .....32AWG , 530 OHMS/KM

Insulation Resistance: .....10M-KM MIN at 20°C DC 500V.  
 (EIA—364—21)

Dielectric Strength: .....AC 500V/1 Minute No Breakdown.  
 (EIA—364—20)

### Physical

Operating Temperature: .....0 ~ 50°C; 15-85% RH (Non-Condensing)

Storage Temperature: .....-25 ~ 70°C; 15-85% RH (Non-Condensing)

P1: .....USB3.1 C Type Male: Contacts Terminal  
 Gold Flash, Nickel Plated Shell; Black  
 Insulation

P2: .....USB3.1 C Type Male: Contacts Terminal  
 Gold Flash, Nickel Plated Shell; Black  
 Insulation

Molding Material: .....Black PVC Conform RoHS - Product is CE  
 marked and conforms to 2011/65/EU  
 RoHS2

DC Output Voltage: .....5.0V/9.0V/12.0V/15.0V

## C-2.6. WALL MOUNT USB TYPE – C INTERCHANGEABLE AC

### ADAPTER/AC CLIP

#### Output

DC Output Voltage: .....5.0V/9.0V/12.0V/15.0V  
 Max Current: .....3.0A/2.0A/1.5A/1.2A  
 Output Power: .....15.0W/18.0W/18.0W/18.0W  
 Regulation: .....± 5%  
 Ripple & Noise P-P(max)<sup>2</sup>:.....200mV Input

#### Input

AC Input Voltage Range:.....90 to 264VAC  
 AC Input Frequency: .....47 to 63Hz  
 Input Current: .....0.5A(RMS) max at 100VAC  
 Inrush Current: .....70A max (Cold Start at ambient 25°C, full load)

#### No Load Power Consumption

At 115VAC Input..... 0.017W

#### No Load Power Consumption

at 230VAC Input ..... 0.015W

115VAC Average Efficiency<sup>3</sup> .....5V: 83.11%, 9V: 86.06%, 12V: 86.37%,  
 15V: 85.91%

230VAC Average Efficiency<sup>3</sup>.....5V: 83.66%, 9V: 87.36%, 12V: 87.0%,  
 15V: 86.83%

230VAC 10% Load Efficiency<sup>3</sup>: ..... 5V: 82.11%, 9V: 82.68%, 12V: 79.93%,  
 15V: 75.94%

Leakage Current .....100uA max Protection

#### Protection

Over-Voltage:.....5V/6.25V max, 9V/11.25V max, 12V/15V  
 max, 15V/18.75V max

Short Circuit:.....Output can be shorted without damage

Over-Current:.....110~135%

Over Temperature: .....Latch off function Environmental

#### Environmental

Operating Temperature: .....	0°C to +40°C
Non-Operating Temperature:.....	-20°C to +70°C
Operating Humidity: .....	5 to +95% Safety Approvals and EMC
Dielectric Withstand (HI-POT):.....	Primary to Secondary: 3600VAC for 2 secs, 3mA
Insulation Resistance: .....	Pri. to Sec.: >30M oh 500VDC
Standards: .....	cULus 62368-1, IEC 62368-1, AS/NZ 60950.1:2011+A1, PSE, CCC, KC, BIS
EMI Emissions: .....	FCC Part 15 Class B, EN 55032/CISPR 32, AS/NZS CISPR 32:2015, KCC Class B Conducted and Radiated
Harmonic Current Emissions: .....	IEC 61000-3-2
Voltage Fluctuations & Flicker:.....	IEC 61000-3-3
Immunity: .....	EN 55024/CISPR 24: IEC 61000-4-2 (+/- 15kV air, +/-8kV contact), IEC 61000-4-3, IEC 61000-4-4, IEC 61000-4-5 (+/-2kV), IEC 61000-4-6, IEC 61000-4-8, IEC 61000-4-11 Mechanical
Dimensions (L x W x H): .....	56.0mm (2.20in) x 40.45mm (1.59in) x 33.9mm (1.33in)
DC Output Connector: .....	USB-C

#### Notes

1. The specifications defined are at ambient temperature of 25°C, unless otherwise specified.
2. 20MHz bandwidth frequency oscilloscope, add a 0.1µF multilayer Cap. and Low ESR Electrolytic Cap. (10µF) at output connector terminals (nominal line voltage, full load).
3. Efficiency is measured after 30 minutes burn-in

## Appendix D: STANDARD COMPLIANCE

The SHOUT sp has an internal Iridium 9523 L-band transceiver. The 9523 is tested to the regulatory and technical certifications shown below. It is assigned to the FCC Identifier Q639523.

Regulatory Approvals	Radio Tests	EMC Tests	Mechanical/ Electrical Tests
CE	ETSI EN 301 441 V1.1.1(2000-05)	ETSI EN 301 489-20 V1.2.1(2002-11) ETSI EN 301 489-1 V1.8.1(2008-04) ETSI EN 301 489-20 V1.2.1(2002-11)	EN60950-1:2006 Part 1
FCC	FCC CFR47 Parts 2, 15, and 25	EN61000-4-2 : 1995/A2 : 2001 Part 4.2 EN61000-4-3 : 2002 Part 4.3 EN61000-4-4 : 2004 EN61000-4-6 : 1996/A1 : 2001 Part 4.6 EN55022:2006	
Industry Canada	Industry Canada RSS170 Issue 2, March, 2011		

The SHOUT sp has an internal Wi-Fi/Bluetooth transceiver. The Wi-Fi/Bluetooth transceiver is tested to the regulatory and technical certifications shown. It is assigned to the FCC Identifier Z64-WL18SBMOD.

## Appendix E: EXPORT COMPLIANCE

The SHOUT sp is controlled by the export laws and regulations of the United States of America (USA). It is the policy of NAL Research to fully comply with all U.S. export and economic sanction laws and regulations. The export of NAL Research products, services, hardware, software and technology must be made only in accordance with the laws, regulations and licensing requirements of the U.S. Government. NAL Research customers must also comply with these laws and regulations. Failure to comply can result in the imposition of fines and penalties, the loss of export privileges, and termination of your contractual agreements with NAL Research.

The export and re-export of NAL Research products and services are subject to regulation by the Export Administration Regulations (15 CFR 730-744), as administered by the U.S. Department of Commerce, Bureau of Industry and Security (“BIS”). See: <https://www.bis.doc.gov/index.php/regulations/export-administration-regulations-ear> for further information on BIS and the Export Administration Regulations (EAR). Additional export restrictions are administered by the U.S. Department of the Treasury’s Office of Foreign Asset Controls (“OFAC”). See: <http://www.ustreas.gov/ofac> for further information on OFAC and its requirements.

## Appendix F: SHOUT sp MOUNT KIT

The SHOUT sp Mount Kit securely holds the SHOUT sp device onto vehicles windshields or hard flat surfaces, while leaving the entire screen and control buttons accessible. It enables charging from vehicular power or from an AC wall mount, and provides remote PTT capability through a handheld speaker-microphone. The handheld speaker-microphone amplifies PTT audio for use in noisy environments. The SHOUT sp Mount Kit supports telephony mode as well as PTT mode. **Figure 121** below depicts the SHOUT sp Mount Suction Cup with car charger. **Figure 122** below depicts the SHOUT sp Mount Screw-Down Plate with an AC Adapter Plug.

The SHOUT sp Mount Kit consists of the following items:

- Suction cup mount or bolt-down mount for temporary or permanent installations
- Double Ball Articulating Arm
- Cradle with grips, speaker/microphone mounting bracket, and audio amplifier module
- Handheld Speaker-Microphone
- USB-C car charging adapter 3ft. cable or AC wall mount charging adapter 6ft. cable
- The SHOUT sp Mount Kit is available on the NAL Research website:

<https://www.nalresearch.com/>



*Figure 121: SHOUT sp Mount (Suction Cup)*



*Figure 122: SHOUT sp Mount (Screw-Down Plate)*

## F-1. SHOUT SP MOUNT COMPONENTS

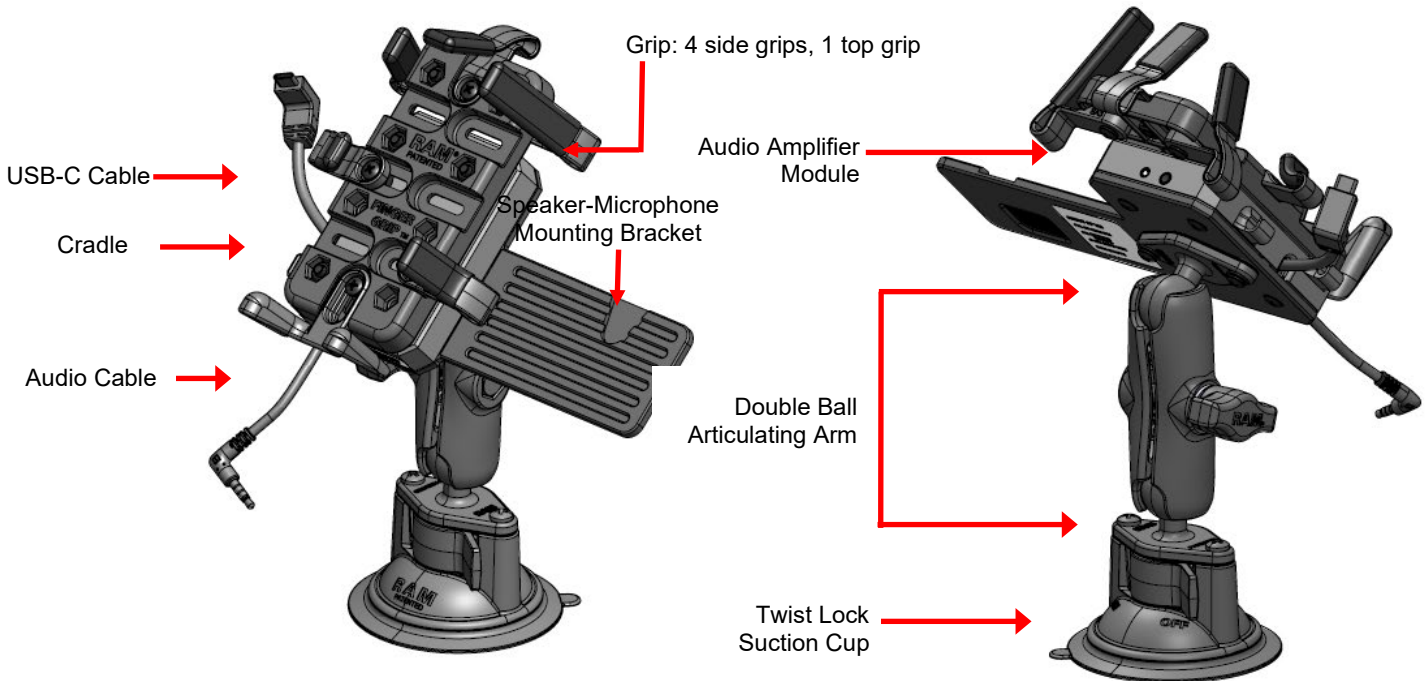
### F-1.1. Twist-Lock Suction Cup Mount

The Twist-Lock Suction Cup Mount has a 3.3" diameter suction cup twist lock base, and a double ball articulating arm (see **Figure 123**). The suction cup base holds on glass and non-porous smooth hard surfaces. The double ball articulating arm is designed with a 1" diameter plastic ball and socket system that has adjustment points at both ends of the double socket arm; allowing for almost infinite adjustment and viewing angles.

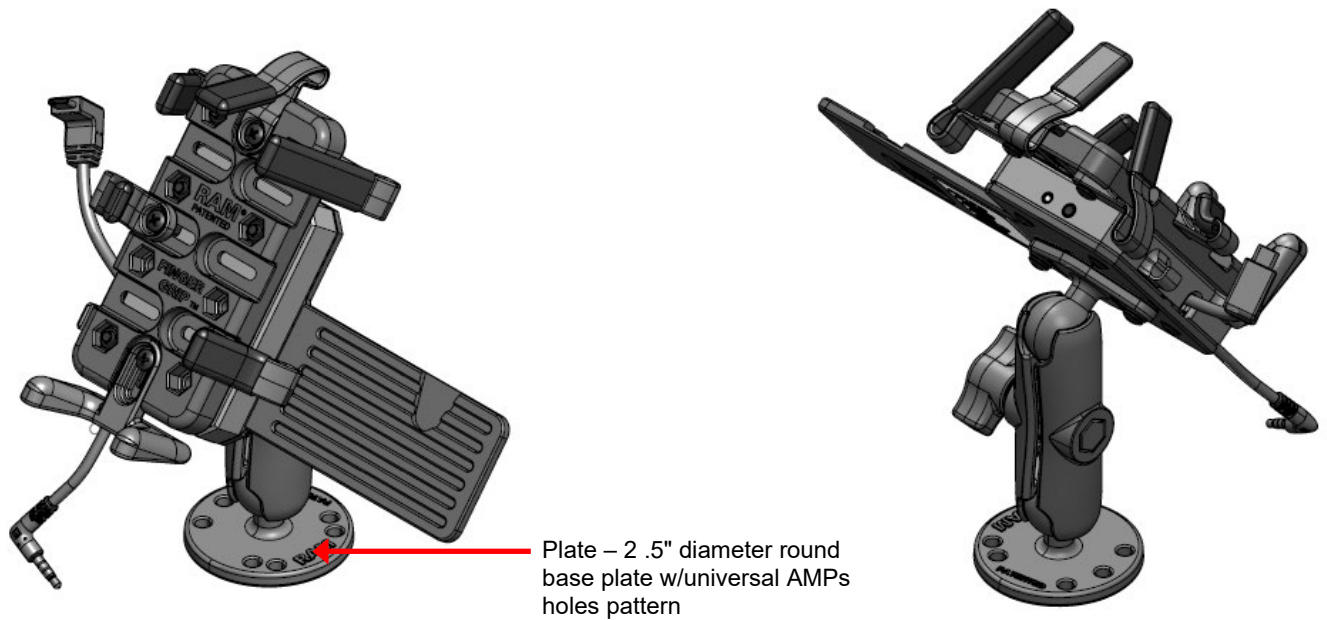
### F-1.2. Screw-Down Plate Mount

The Screw-Down Plate Mount has a composite 2.5" diameter round base (see **Figure 124**), and a double ball articulating arm (see **Figure 123**). The double ball articulating arm is designed with a 1" diameter plastic ball and socket system that has adjustment points at both ends of the double socket arm; allowing for almost infinite adjustment and viewing angles.





*Figure 123: Kit with Twist-Lock Suction Cup Mount*



*Figure 124: Kit with Screw-Down Plate Mount*

### F-1.3. Cradle Assembly

The Cradle assembly includes the following components (see Figure 125, Figure 126, and Figure 127):

- Cradle body with grips
- Speaker/microphone mounting bracket
- Audio Amplifier Module
  - USB-C cable
  - Audio cable (3.5mm)

### F-1.3.1. Grip

The Cradle body has five (5) grips that securely holds the SHOUT sp device in the Cradle. The SHOUT sp device wedges in and out of the Cradle body by flexing the grips (see **Figure 125**).

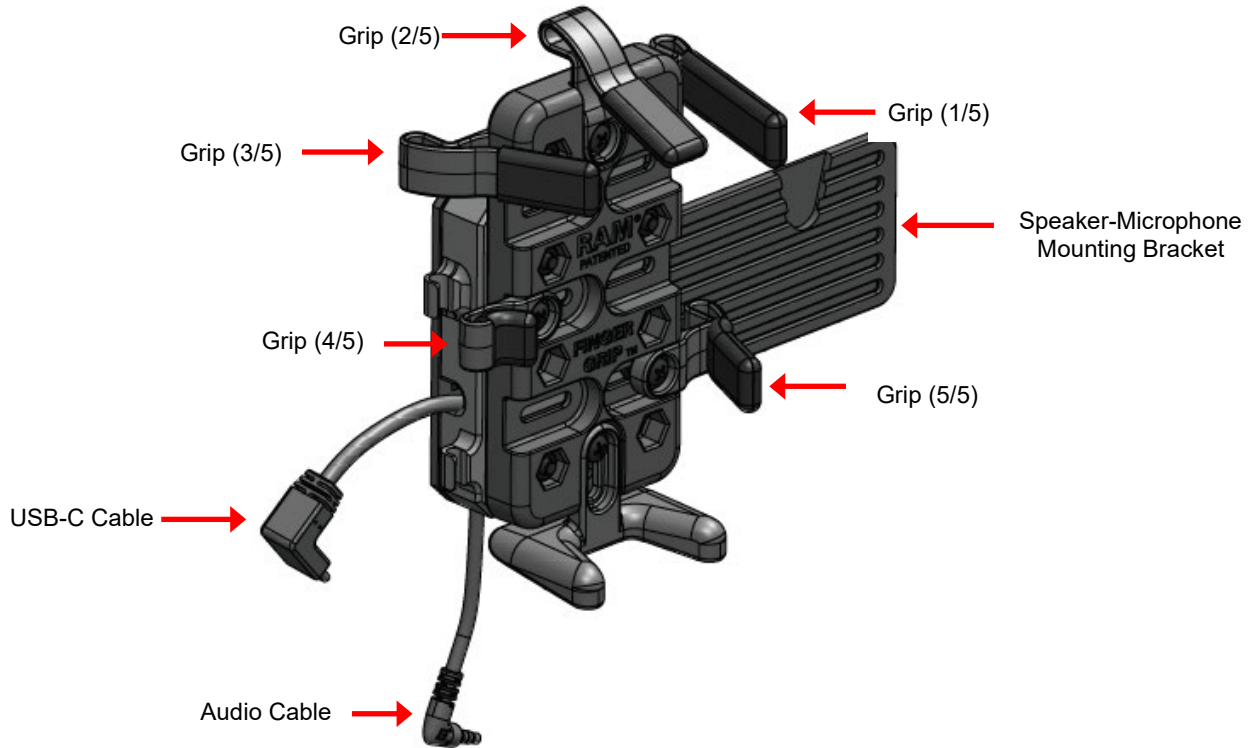
### F-1.3.2. Audio Amplifier Module

The Audio Amplifier Module features include the following:

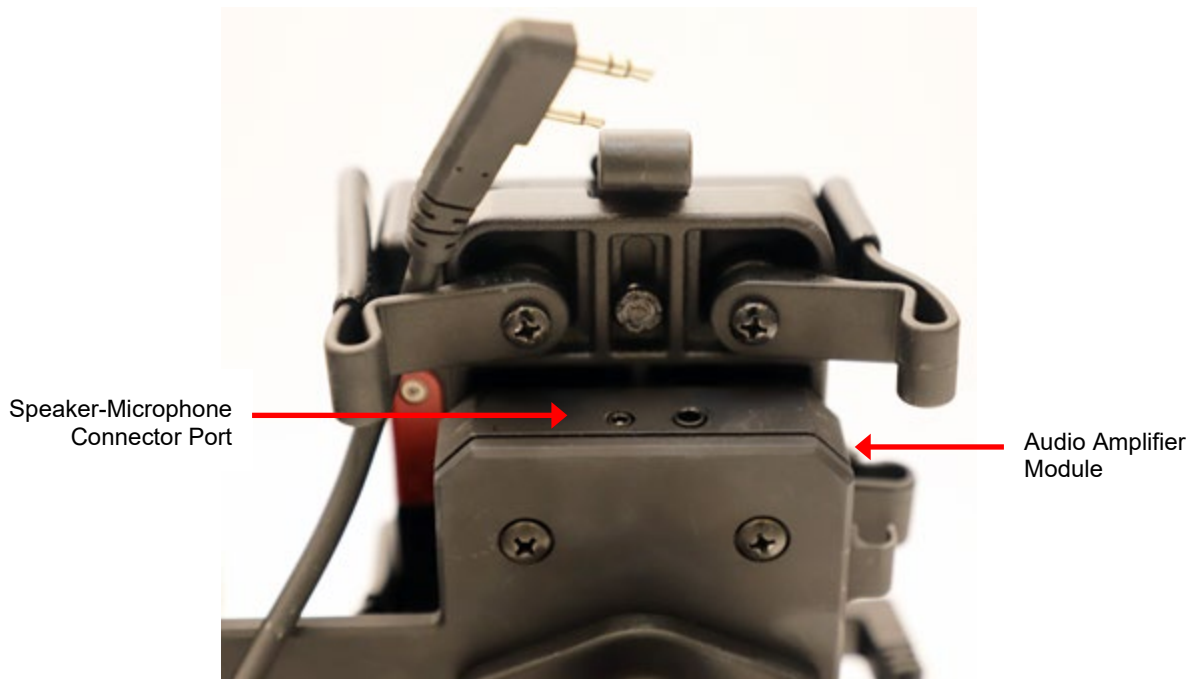
- Provides power charging to the mounted SHOUT sp device when the USB-C cable from the Audio Box is attached to mounted SHOUT sp device USB-C connector port, and when a USB-C charging power cable is connected to the Audio Amplifier Module USB-C connector port with power applied. (See **Figure 125 through Figure 129**).
- Provides/switches PTT speaking/hearing features from the SHOUT sp device to the Speaker-Microphone when the Speaker-Microphone cable is connected to the Audio Amplifier Module, and the Audio cable connector from the Audio Amplifier Module is attached to the Audio connector port on the SHOUT sp device.

**IMPORTANT:** The SHOUT sp Mount only functions when power is applied to the Audio Amplifier Module.

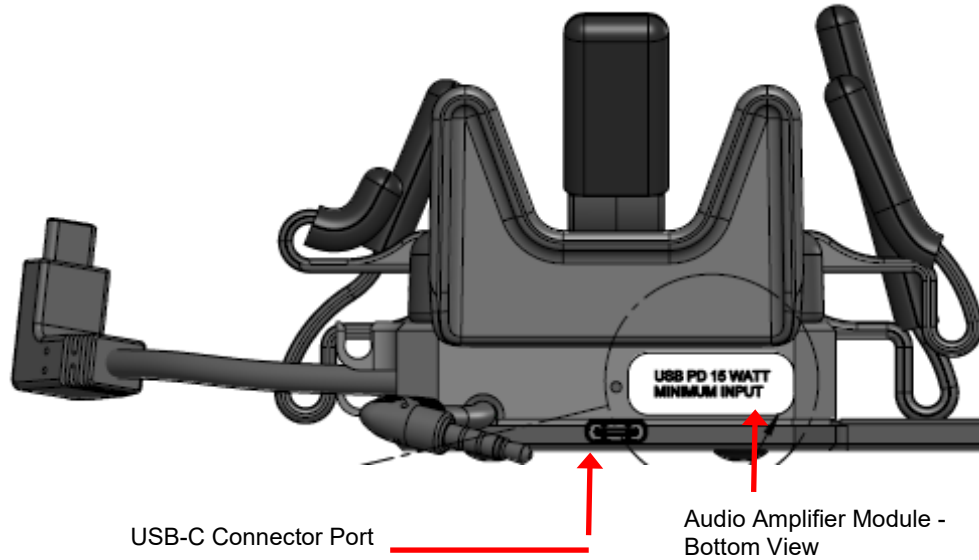
**NOTE:** (See **Figure 125 through Figure 129**).



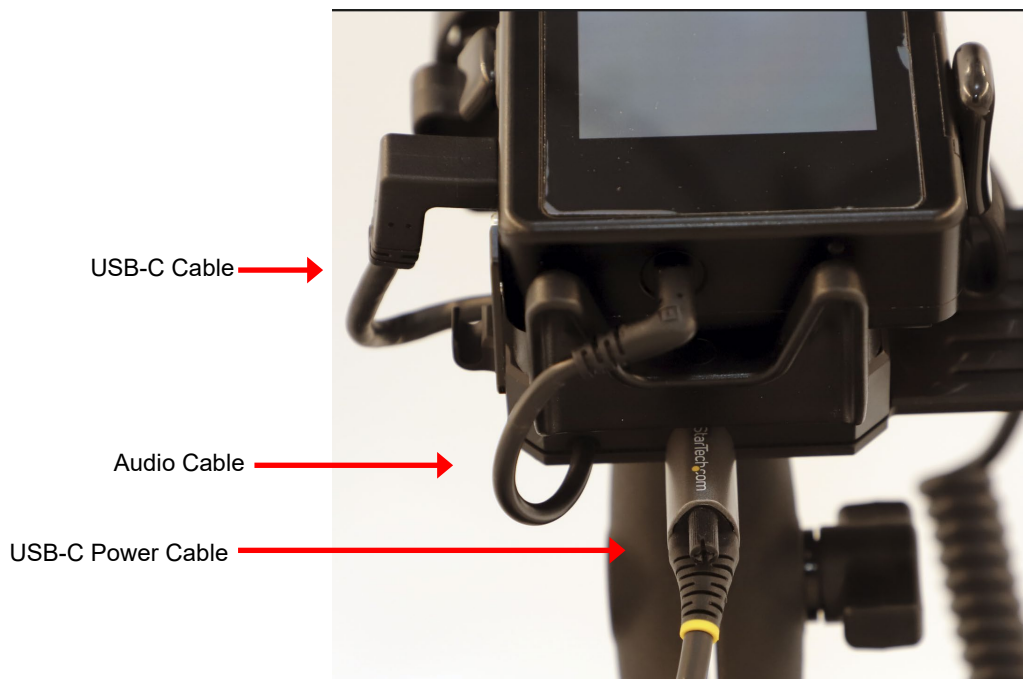
*Figure 125: Cradle Assembly – Front View*



*Figure 126: Cradle Assembly – Top View*

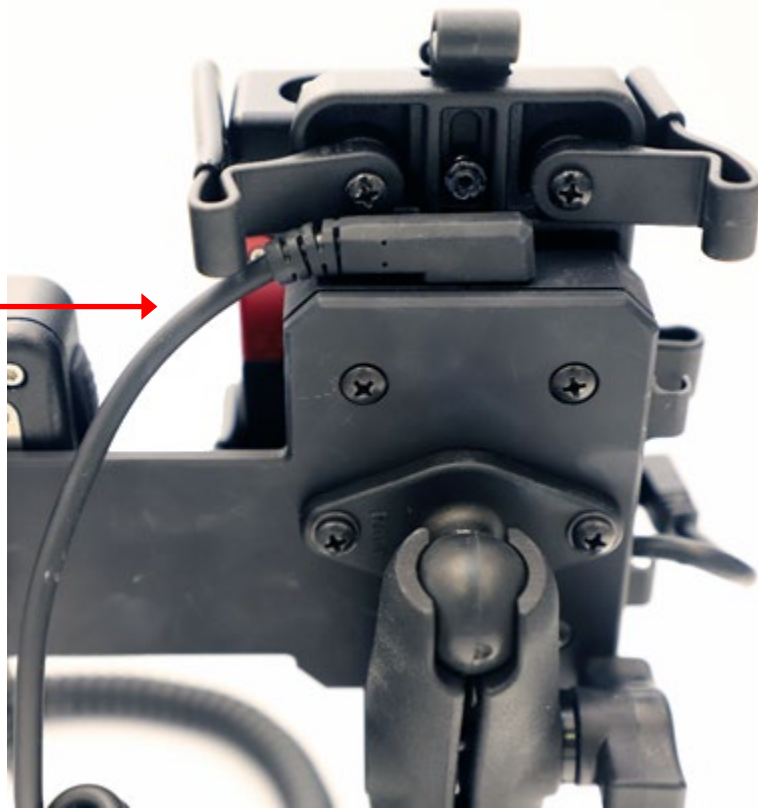


*Figure 127: Cradle Assembly – Bottom View*



*Figure 128: Bottom View: Audio Amplifier Module*

Speaker-Microphone  
Cable



*Figure 129: Top View: Audio Amplifier Module*

## F-1.4. Handheld Speaker-Microphone

The Handheld Speaker-Microphone is a waterproof speaker microphone with a PTT button for two-way communication (**Figure 131**). The Handheld Speaker-Microphone 3.5 mm cable connects to the Audio Connector port on top-side of the Audio Amplifier Module (see **Figure 129**). The Mount Clip located on the Backside of the Handheld Speaker-Microphone is a spring-loaded clip that allows you to position-lock the Handheld Speaker-Microphone onto the notch groove on the Speaker-Microphone bracket (Figure 132). The Handheld Speaker-Microphone features include:

- Heavy duty cable
- Waterproof IP67 rated
- High / low volume toggle button
- Large PTT button, operable with gloves
- Sealed 3.5mm audio jack



*Figure 130: Front View*



*Figure 131: Partial Side View*



*Figure 132: Rear View*

## F-1.5. Car Charger

The Car Charger connects to a car charging port, and a USB-C power cable (6ft) connects to the car charger USB-C connector port (see Figure 134). The USB-C connector delivers up to 55W of charging, and is equipped with an intelligent chip that protects against sharp spikes in current, voltage, and temperatures.



*Figure 133: Car Charger*



*Figure 134: Car Charger USB-C Power Cable (3ft)*

## F-1.6. Car Charger USB-C Power Cable

The Car Charger Power Cable is a three (3) ft. top screw locking USB C cable USB3.1/3.2 Gen 2 Type C Cable, 100W/5A, DP Alt Mode (see **Figure 134**). The car charger USB-C cable connects to and applies power to the Audio Amplifier module (see **Figure 128**), which in turn charges the mounted SHOUT sp device.

**NOTE:** Only one (1) USB-C connector has the top screw locking, which is connected to the USB-C connector port at the bottom of the Audio Amplifier Module.

## F-1.7. AC Wall Mount Power Cable

The AC Wall Mount Power Cable is a six (6) ft. USB-C to C 2.0 male-to-male cable used to connect power to a Mount (Suction Cup and Bolt-Down) via the Audio Amplifier Module from an AC wall mount. It is a USB-C to C 2.0 male-to-male cable that supports 3A charging output, and the USB-C connectors have a reversible symmetrical design that is identical on both sides (see **Figure 135**).



*Figure 135: Docking Station Power Cable (6ft)*

## F-1.8. AC Adapter Wall Mount w/AC Clip

The AC Adapter Wall Mount provides DC output voltages of 5V/9V/12V/15V and a current of 3A/2A/1.5A/1.2A in a single adapter. **Figure 136** depicts an AC Adapter Wall mount with a United Kingdom (UK) AC clip.



*Figure 136: Wall Mount AC Interchangeable Adapter*

AC clips mate with the AC Adapter Wall Mount. There are two (2) types of compatible AC clips: one for the US, and one for the UK (see **Figure 137** and **Figure 138**).



*Figure 137: AC Clip - USA*



*Figure 138: AC Clip – UK*

## F-2. INSTALLATION

### F-2.1. SHOUT sp Mount (Suction Cup)

1. Position the SHOUT sp Mount (Suction Cup) over a clean glass surface or a clean non-porous smooth surface, or metal or stone (ex: glass, plastic, or metal).
2. Lock-down the SHOUT sp Mount (Suction Cup) into position by twisting the Suction Cup base clockwise, and sliding the lock toggle switch to the lock position (see **Figure 139**).





Figure 139: Suction Cup Mount

## F-2.2. SHOUT SP Mount (Screw-Down Plate)

1. Prepare the surface by drilling holes using the template shown in **Figure 140** below.

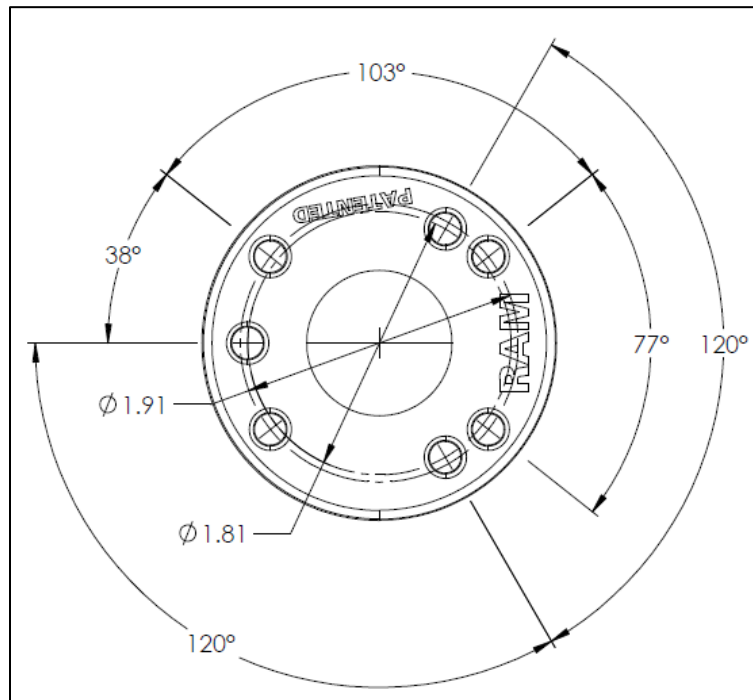


Figure 140: Template

2. Affix the SHOUT sp Mount (Screw-Down Plate) into position by drilling two holes for two (2) #8 X 1/2" Phillips rounded head self-tapping screws using a .136 drill bit into the existing two slotted hole patterns on the Screw-Down Plate(see **Figure 141**).

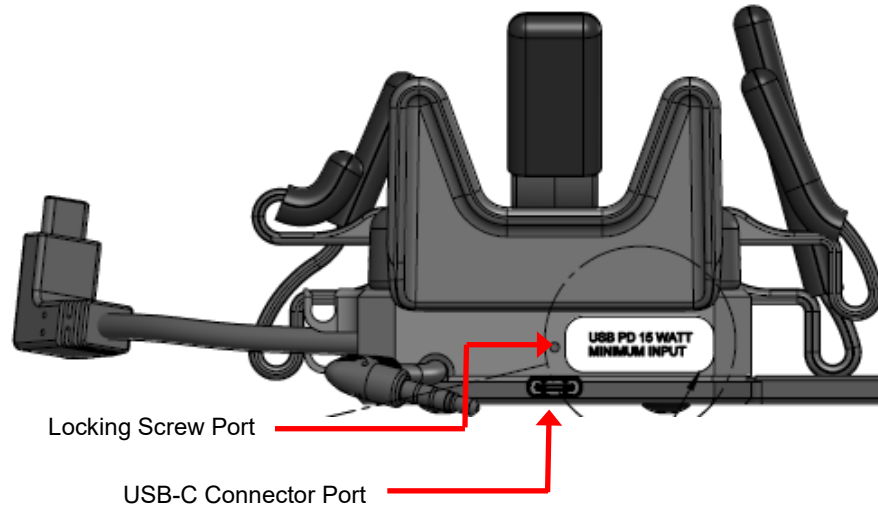
**NOTE:** The #8 X 1/2" Phillips rounded head tapping screws are included in the SHOUT sp Mount kit.



*Figure 141: Screw-Down Mounting Plate*

### F-2.3. Car Charger

1. Attach the USB-C connector (with a top locking screw) from the Power USB-C cable (3ft) to the USB-C connector port on the bottom of the Audio Amplifier module. After which, screw down the top locking screw into the top locking screw port adjacent to the USB-C connector port (see **Figure 142**).



*Figure 142: Cradle Assembly – Bottom View*

2. Attach the other USB-C connector (without a locking screw) from the Power USB-C cable (3ft) to the to the USB-C connector port on the Car Charger (see **Figure 143**).



*Figure 143: Power USB-C Cable Connected to Car Charger*

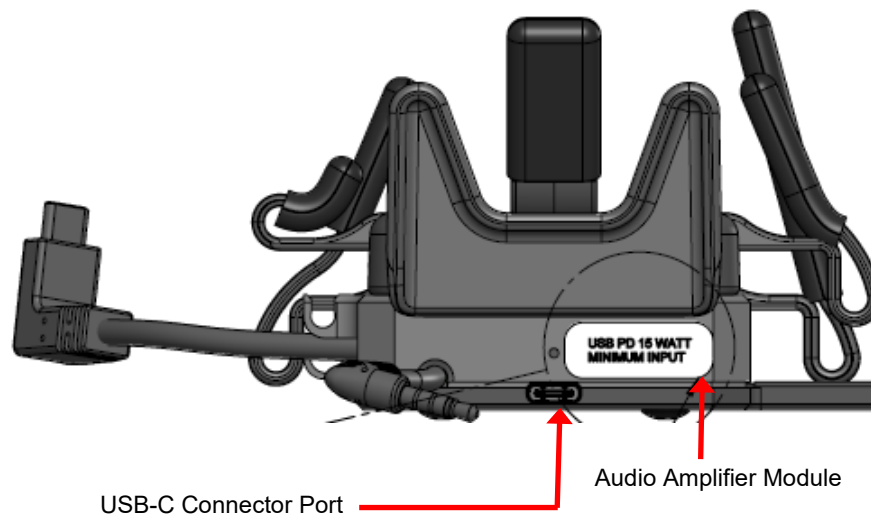
## F-2.4. AC Adapter Wall Mount

1. Attach the appropriate AC Clip (US or UK) to the AC Adapter Wall Mount.
2. Plug the AC Adapter Wall Mount into an AC Wall outlet.
3. Attach the USB-C connector from one end of the Power USB-C cable (6ft) to the USB-C connector port on the AC Adapter Wall Mount (see **Figure 144**)



*Figure 144: USB-C Connection AC Adapter Wall Mount*

4. Attach the other USB-C connector at the other end of the Power USB-C cable to the Power USB-C connector port on the bottom of the Audio Amplifier Module (see **Figure 145**).



*Figure 145: USB-C Connector Port on Audio Box*

### **F-3. LOAD AND OPERATE SHOUT SP DEVICE**

1. Power on your SHOUT sp device. Refer to section 2.4 Power On/Off & Awaken, Reboot.
2. Configure your SHOUT sp device for PTT. Refer to section 9 NAL Push-to-Talk [PTT] App.

- Carefully slide and push your SHOUT sp device from underneath up and through the cradle, until it is secured by the grips (see **Figure 146**).



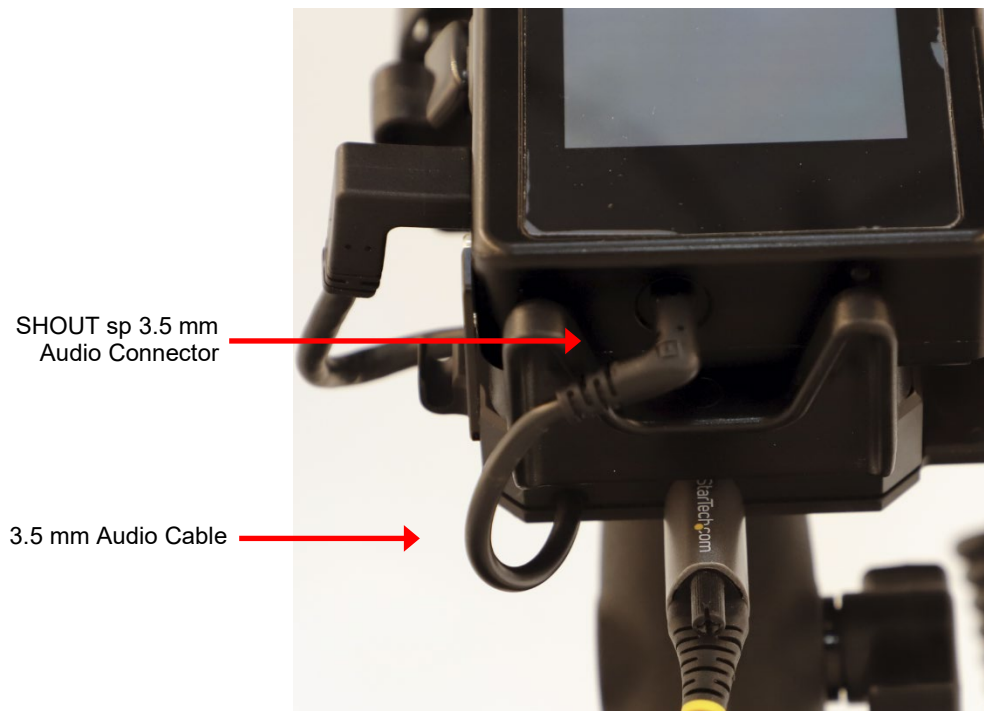
*Figure 146: Mounted SHOUT Sp Device*

- Attach the USB-C connector at the end of the USB-C cable from the Audio Amplifier Module to the USB-C connector port on the side of the SHOUT sp device (see **Figure 147**).



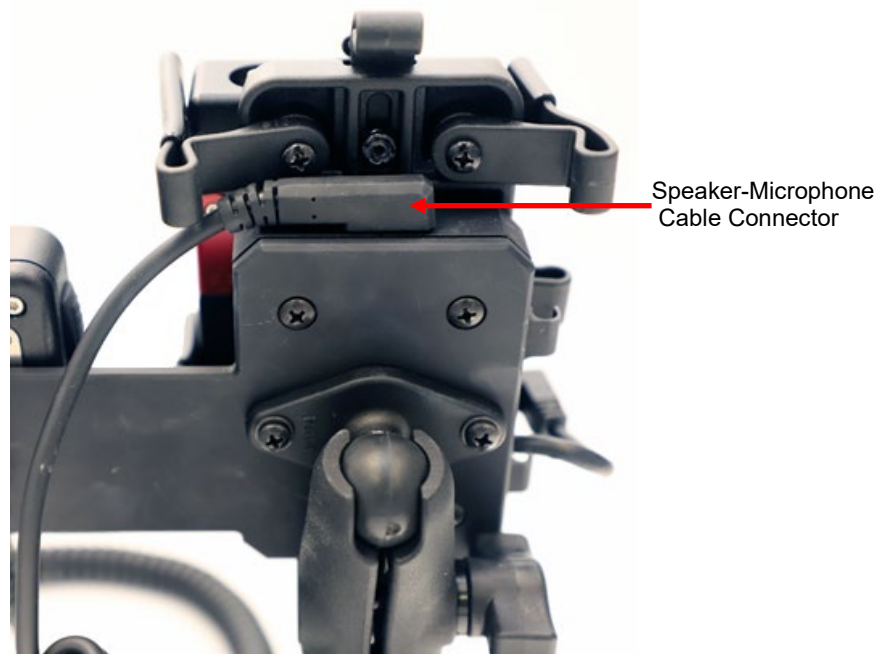
*Figure 147: USB-C Interface Connection*

5. Attach the connector at the end of the Audio 3.5 mm cable from the Audio Amplifier Module to the 3.5 mm Audio connector port on the bottom of the SHOUT sp device (see **Figure 148**).



*Figure 148: Audio Interface Connection*

6. Attach the connector at the end of the Speaker-Microphone dual prong cable to the connector port on top of the Audio Amplifier Module (see **Figure 149**).



*Figure 149: Speaker-Microphone Cable Connected to Audio Box*

7. Press open, insert and release the Speaker-Microphone clip (see **Figure 150**) onto the groove notch of the Speaker-Microphone mounting bracket (see **Figure 151**).



*Figure 150: Handheld Speaker-Microphone Clip*



*Figure 151: Speaker-Microphone Mounting Bracket*

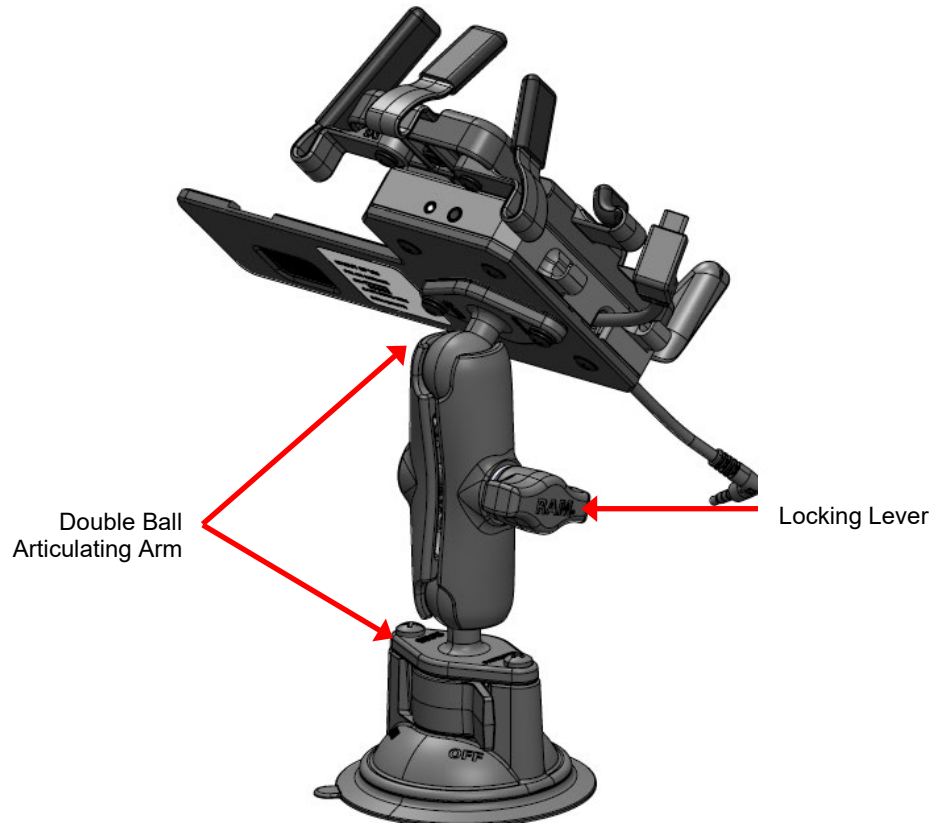
8. If not already done, attach the Power USB-C connector/cable to the USB-C port on the bottom of the Audio Box (see **Figure 152**).





*Figure 152: Power Connection to Audio Box*

9. Loosen the Plastic Ball Socket System by turning the Locking Lever counter-clockwise on the Mount (see **Figure 153**).



**Figure 153: Rubber Ball Socket System**

10. Adjust the mounted SHOUT sp device to the desired position via the Plastic Ball Socket System (see **Figure 153**).
11. Once the desired position of the SHOUT sp device is attained, lock-down the Rubber Ball Socket System by turning the Locking Lever clockwise on the Mount (see **Figure 153**).
12. Adjust the volume on the SHOUT sp as required, and as necessary adjust the volume from the Speaker-Microphone by toggling the Hi / Low toggle switch (see **Figure 154**).
13. Press the *PTT switch* on the Speaker-Microphone to talk, and release the PTT switch to listen (see **Figure 154**).



*Figure 154: Speaker-Microphone PTT Switch and Hi/Low Toggle Switch*